



GAIA TECH

Data Sheet

Customer:

Part No:

Sample No:

Description:

Item No:

GTG-9025A-5V

BUZZER

Customer			
Check	Inspection	Approval	Date



1. Electrical Characteristics

Oscillation Frequency (Hz)	2700
Operating Voltage (V _{p-p})	4 ~7
Rated Voltage (V _{p-p})	5
Current Consumption (mA/max.)	80 at Rated Voltage
Sound Pressure Level (dB/min.)	85 at 10cm at Rated Voltage
Coil Resistance (Ω)	30±3
Operating Temperature (°C)	-40 ~ +80
Storage Temperature (°C)	-40 ~ +85

PS : V_{p-p} = 1/2duty , square wave

2. Typical Frequency Response Curve



ESC End

D A S Frequency Response

i

Distance Loudsp.- Mic.: 10.0 cm

M0:

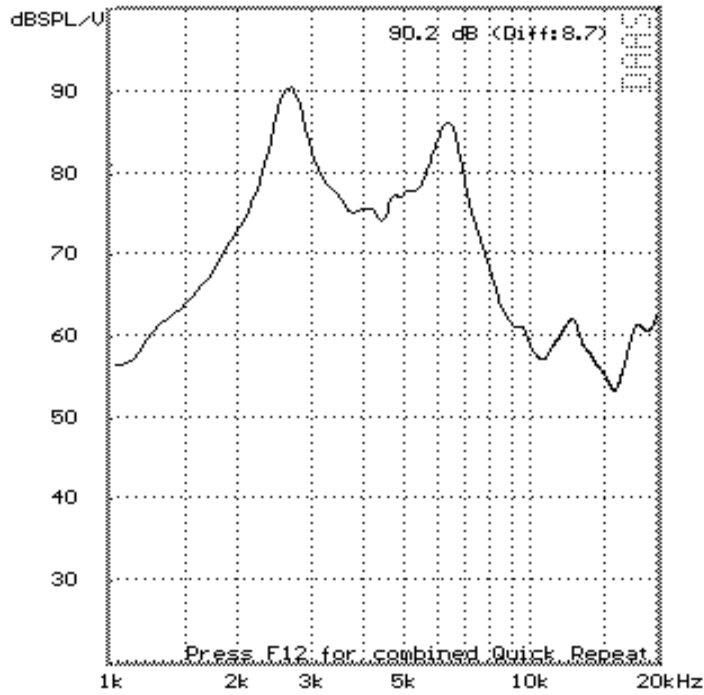

3. Dimensions and Material

3-1 Shape

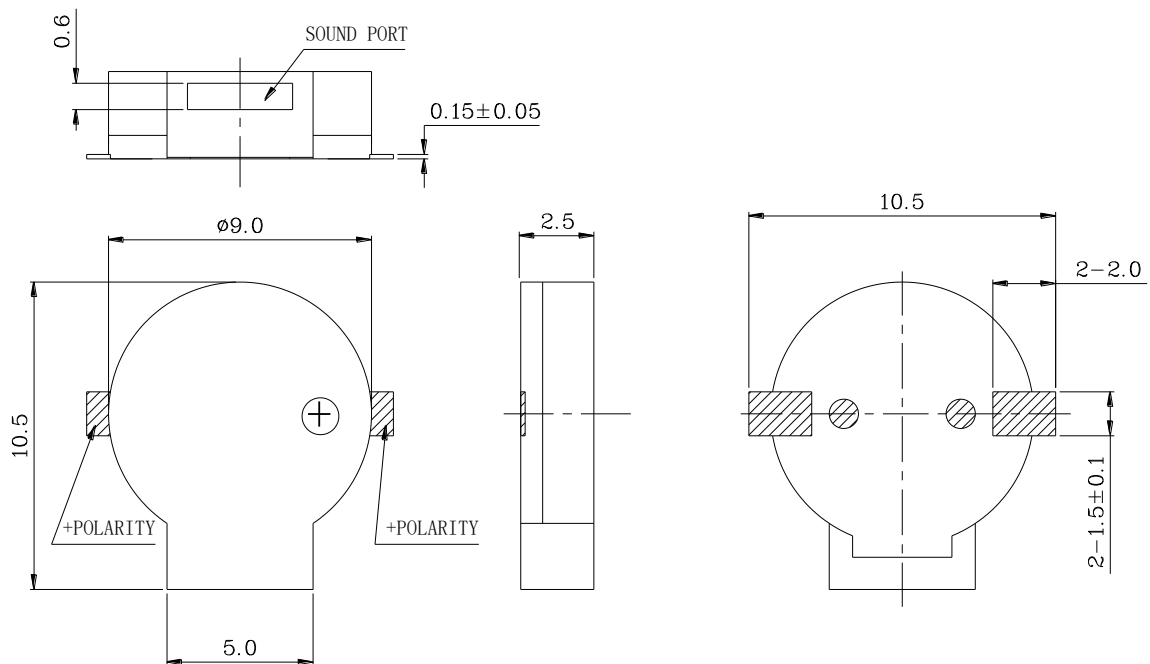

Unit : mm Tol: ±0.3



3-2 Material

Housing	LCP plastic resin (Color : Black)
Leading Pin	Tin Plated Brass
Weight (Gram)	0.8

4.Recommend Driving Circuit

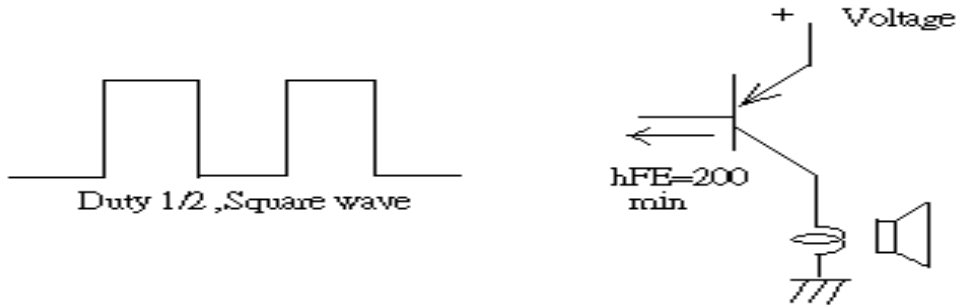

The base current I_b should high enough so that it saturates the collector current of the transistor with the CB load.

5. TESTING METHOD

· *Standard Measurement conditions*

Temperature: $25 \pm 2^\circ\text{C}$ Humidity: 45-60%

· *Acoustic Characteristics*

The oscillation frequency, current consumption and sound pressure are measured by the measuring instruments shown below.

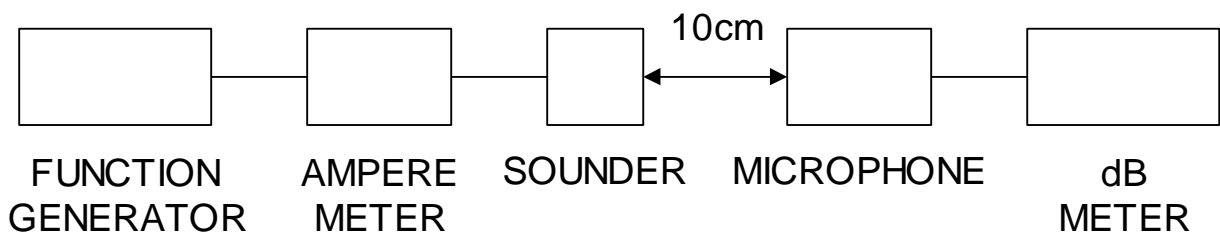



In the measuring test, buzzers is placed as follows:

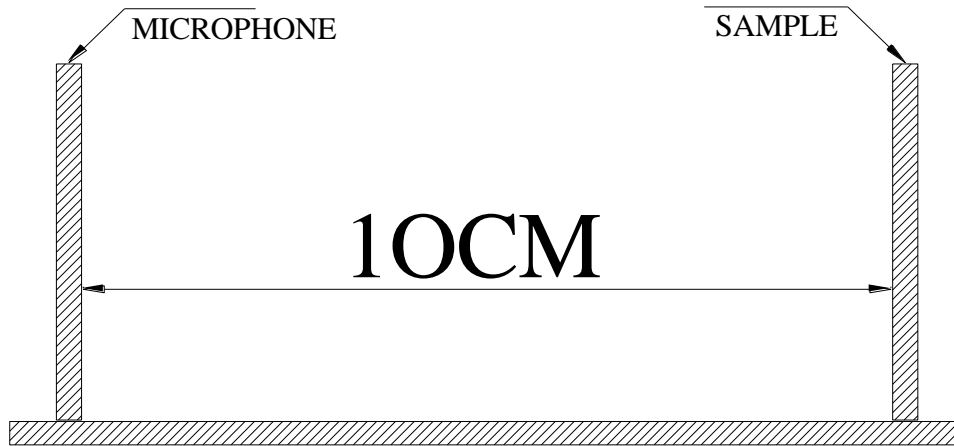

6. RELIABILITY

ITEMS	METHOD OF TEST AND MEASUREMENTS	PERFORMANCE
<i>Coldness withstanding</i>	<i>After 98 hours of being exposed to -30°C environment, should be returned to normal environment for 2 hours, then re-proceed to test.</i>	<i>No abnormality shall exist</i>
<i>Hotness withstanding</i>	<i>After 98 hours of being exposed to +80°C environment, should be returned to normal environment for 2 hours, then re-proceed to test.</i>	<i>No abnormality shall exist</i>



<i>Humidity withstanding</i>	<i>After 98 hours of being exposed to 40°C 95%RH environment in actual operation, should be returned to normal environment for 2 hours, then re-proceed to test.</i>	<i>No abnormality shall exist</i>
<i>Durability</i>	<i>Testing after 1,000 hours actual continuous operation. (at standard measurement conditions)</i>	<i>No abnormality shall exist</i>
<i>Drop withstanding</i>	<i>A natural drop from 75cm high down to the ground.</i>	<i>No abnormality shall exist</i>
<i>Vibration withstanding</i>	<i>Vibration of 2,000 cycles per minute, 2mm amplitude, applied in X, Y and Z directions for 30 minutes each.</i>	<i>No abnormality shall exist</i>

7. Soldering Condition

(1) Recommendable reflow soldering condition is as follows
(Reflow soldering is twice)

Note: It is requested that reflow soldering should be executed after heat of product goes down to normal.

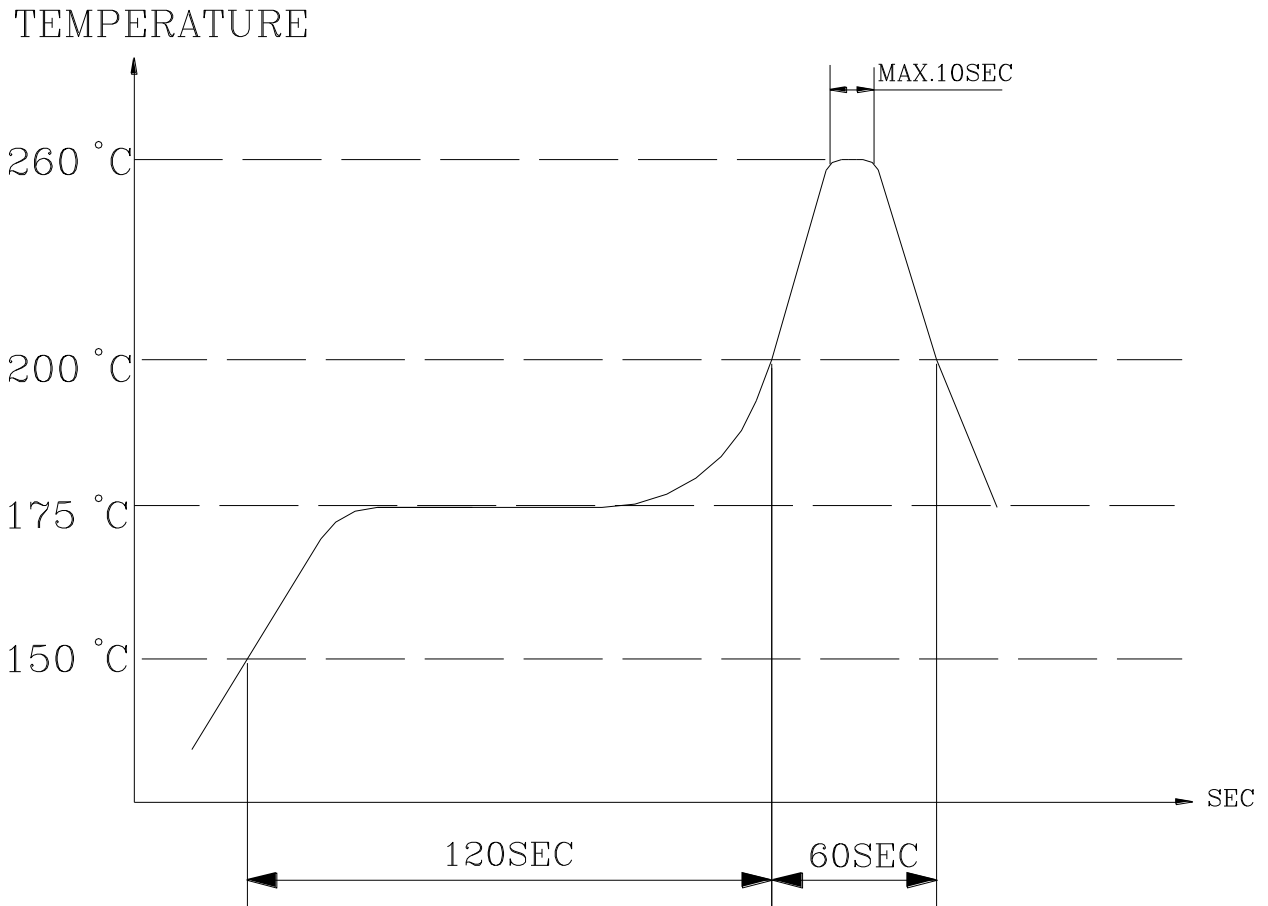

Heat resistant line

(Used when heat resistant reliability test is performed)

(2) Manual soldering

Manual soldering temperature 350°C within 10 sec.

8. PACKAGE METHOD



CARRIER REEL
1000 PCS BUZZER

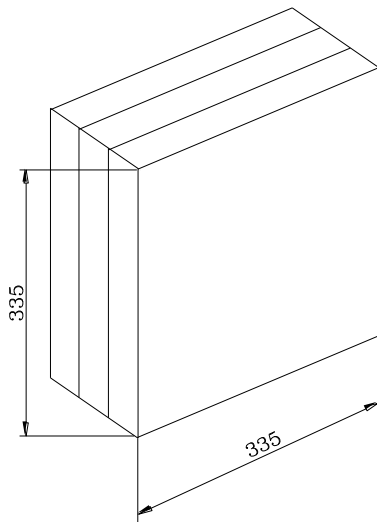
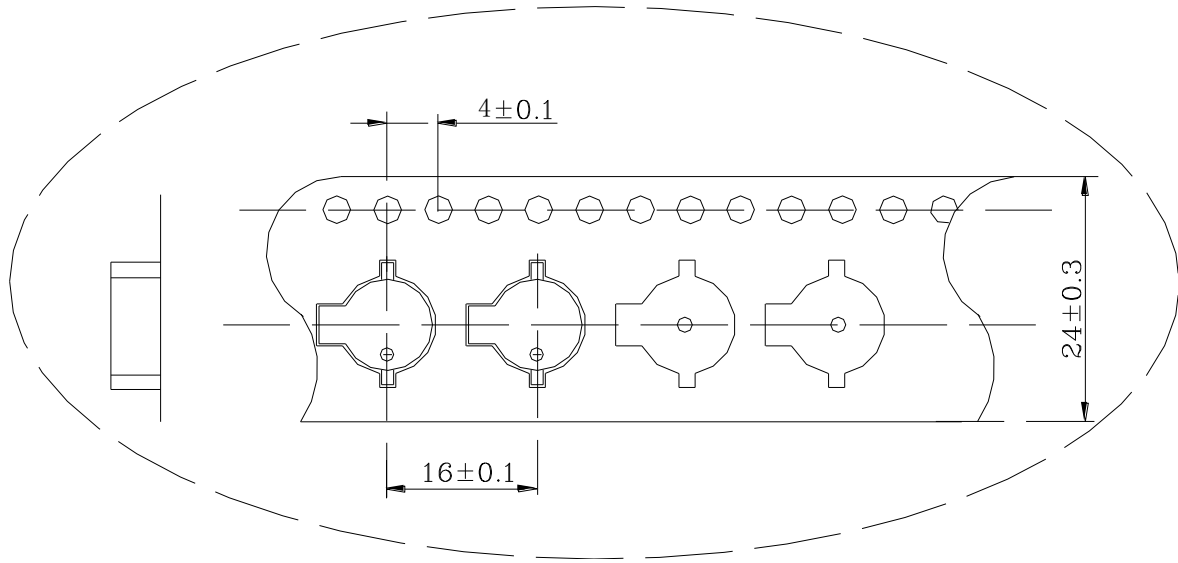
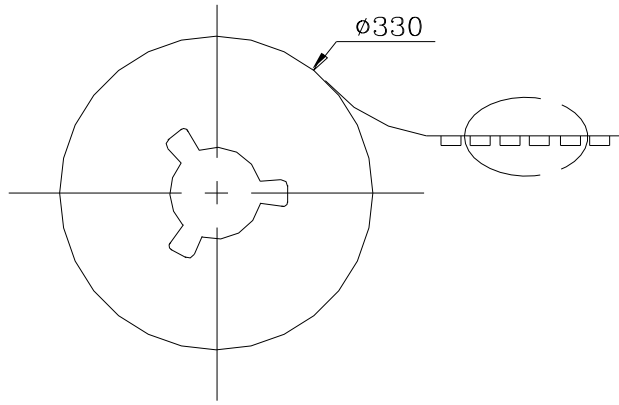

INNER BOX
1 ROLL CARRIER REEL

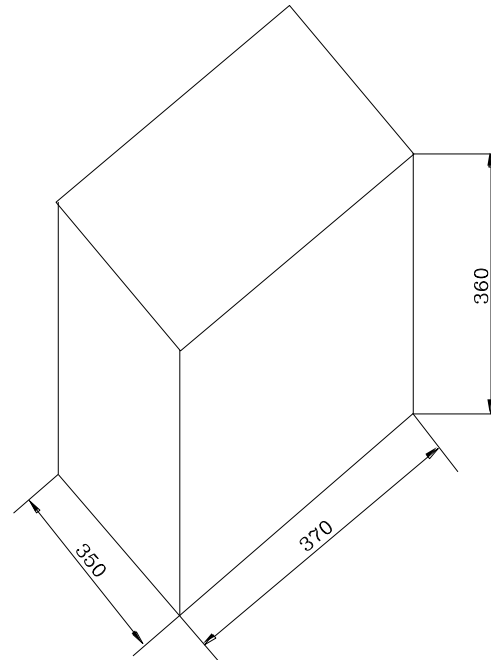

CARTON BOX
10 INNER BOX
10K PCS BUZZER

Unit:mm