



Data Sheet

Customer: _____

Part No: _____

CL-SP175UHRUYG-02

Sample No: _____

Description: _____

Item No: _____

Customer			
Check	Inspection	Approval	Date

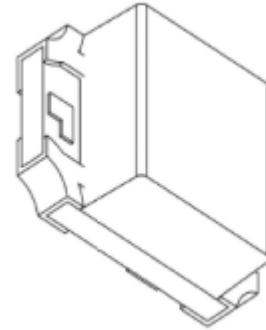

Features

- .0805 package
- .Side view
- .Compatible with infrared and vapor phase reflow solder process.
- .Wide viewing angle
- .Pb-free
- .RoHS compliant

Description

- .The CIELLIGHT 0805 SMD LED is much smaller than lead frame type components,thus enable smaller board size, higher packing density,reduced storage space and finally smaller equipment to be obtained.
- .Besides,lightweight makes them ideal for miniature applications etc.

Applications

- .General lighting
- .Decorative and Entertainment Lighting
- .Indicators
- .Automotive Telecommunication
- .Switch lights

Device Selection Guide

Chip Material		Emitted Color	Resin Color
R6	InGaAlP	Brilliant Red	Water Claer
G2	AlGaInP	Brilliant YellouGreen	

Absolute Maximum Ratings (Ta=25°C)

Parameter	Red	YellowGreen	Units
Power dissipation	55	55	mW
DC Forward Current	25	25	mA
Peak Forward Current [1]	100	100	mA
Reverse Voltage	5	5	V
Operating/Storage Temperature	-40°C To +85°C		

Note:

1/10 Duty Cycle, 0.1ms Pulse Width.

Electro-Optical Characteristics (Ta=25°C)

Parameter	Symbol	Min.	Typ.	Max.	Unit	Condition	
Reverse Current	I_R	---	---	10	μA	$V_R=5V$	
Viewing Angle	$2\theta_{1/2}$	---	120	---	deg	$I_F=20mA$	
Forward Voltage	V_F	R6	1.8	---	2.4	V	$I_F=20mA$
		G2	1.8	---	2.4		
Luminous Intensity	I_v	R6	100	---	200	mcd	$I_F=20mA$
		G2	20	---	40		
Doninant Wavelength	λ_d	R6	620	---	630	nm	$I_F=20mA$
		G2	565	---	575		

Notes:

- 1.Tolerance of Luminous Intensity $\pm 10\%$.
- 2.Tolerance of Forward Voltage : $\pm 0.1V$.
- 3.Tolerance of Dominant Wavelength: $\pm 1nm$

Package Dimensions

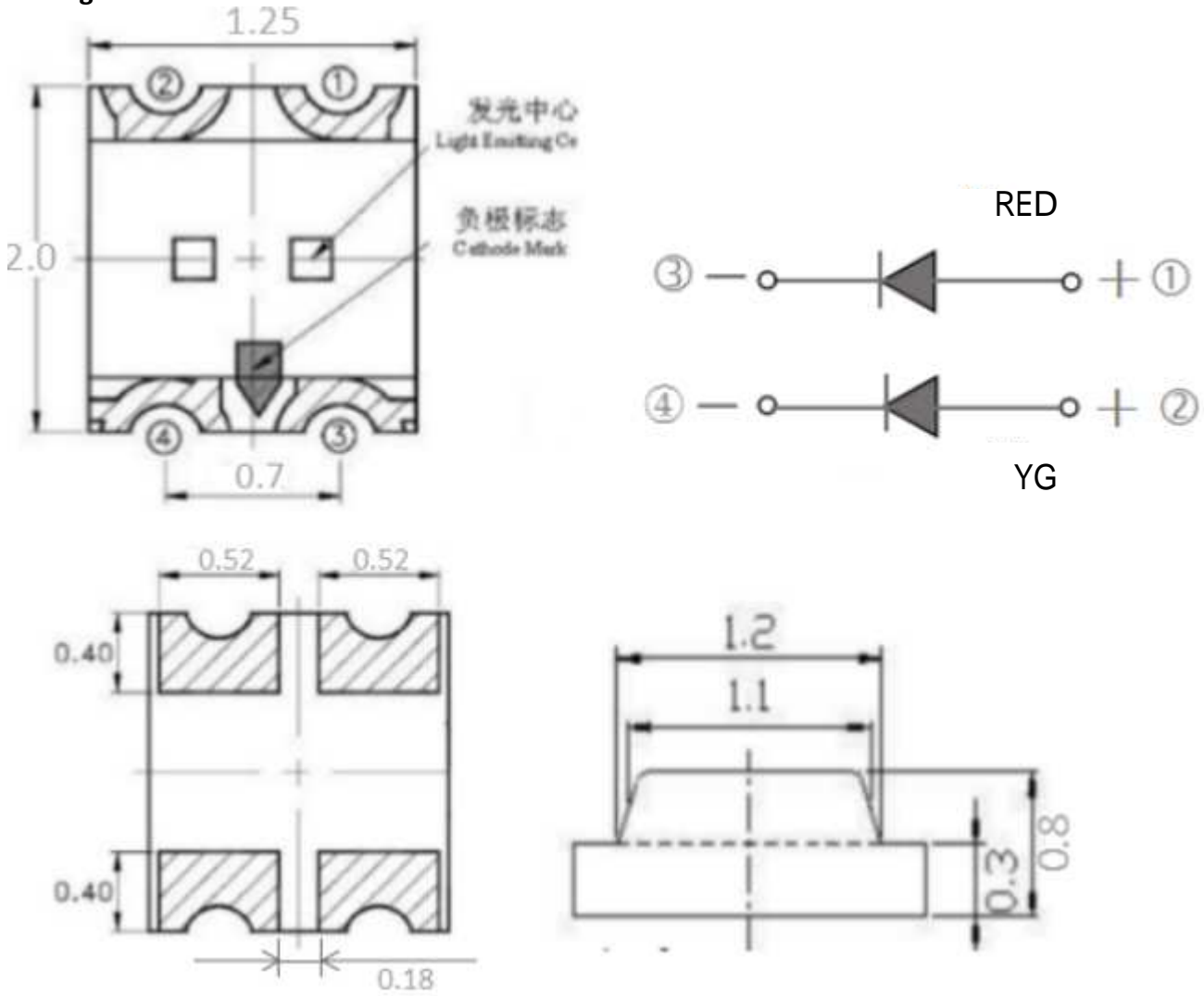

Note: Tolerance unless mentioned is ± 0.1 mm, Unit = mm.

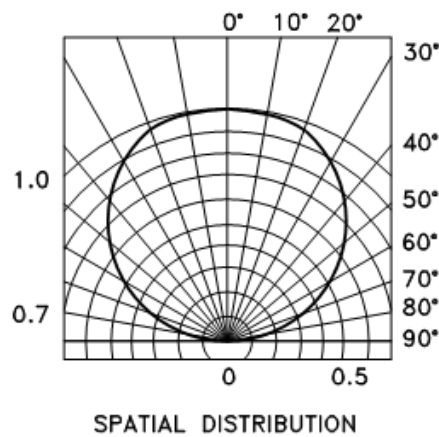
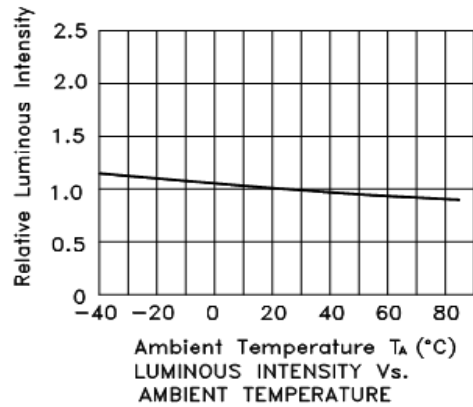
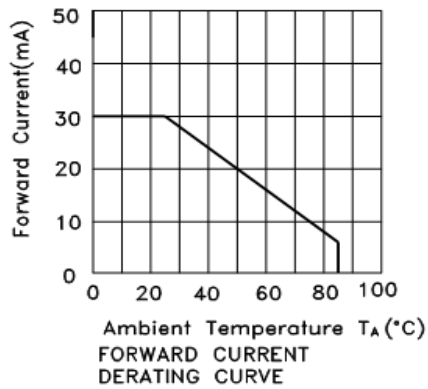
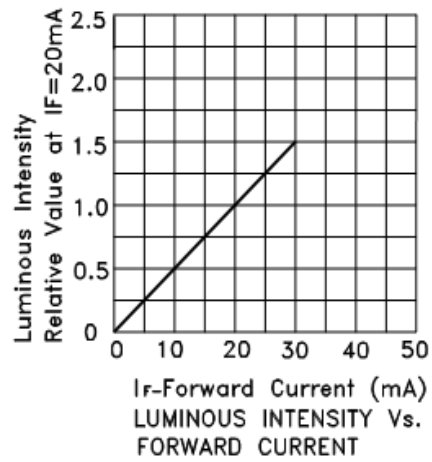
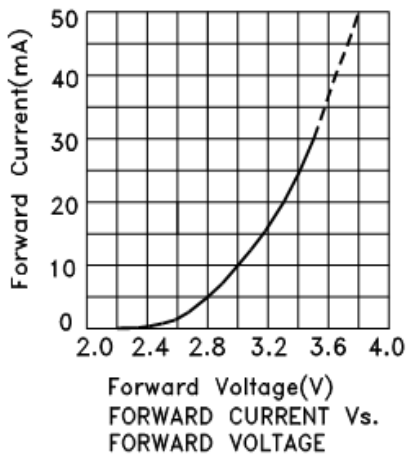
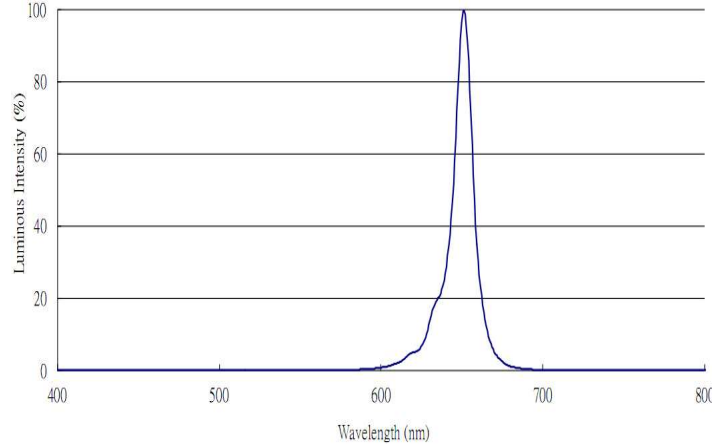

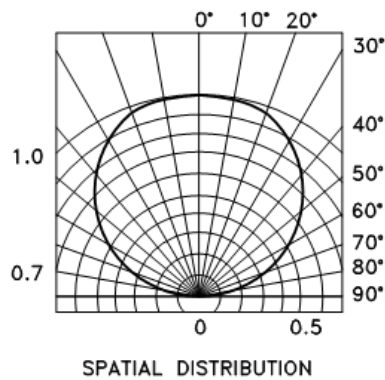
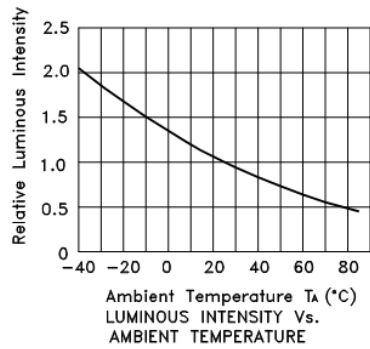
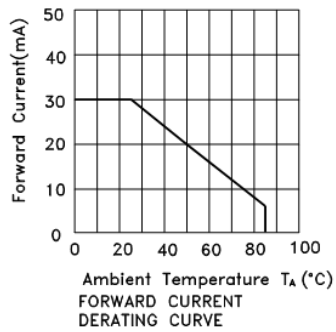
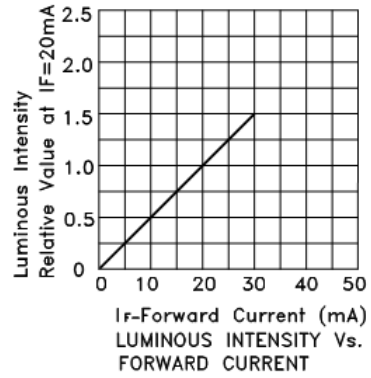
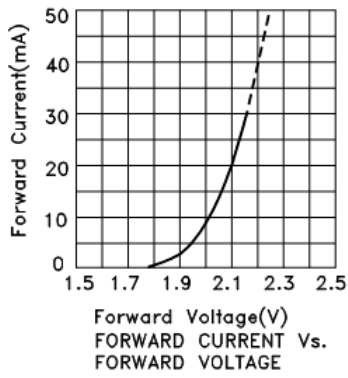
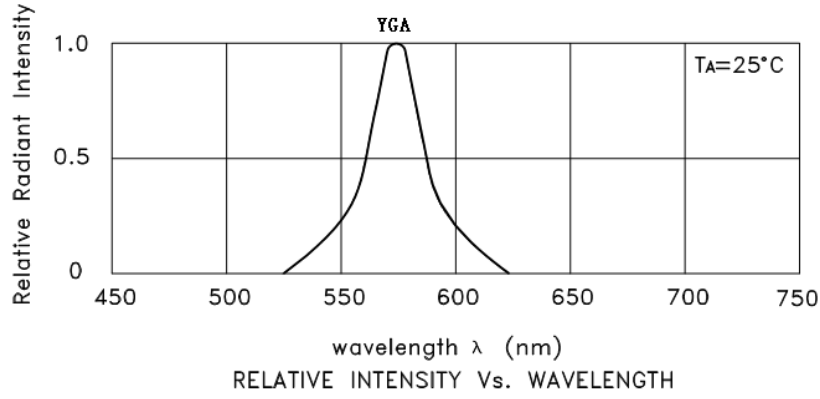

Label Form Specification

CPN: Customer's Production Number
 P/N : Production Number
 QTY: Packing Quantity
 CAT: Ranks
 HUE: Peak Wavelength
 REF: Reference
 LOT No: Lot Number

Reel Dimensions

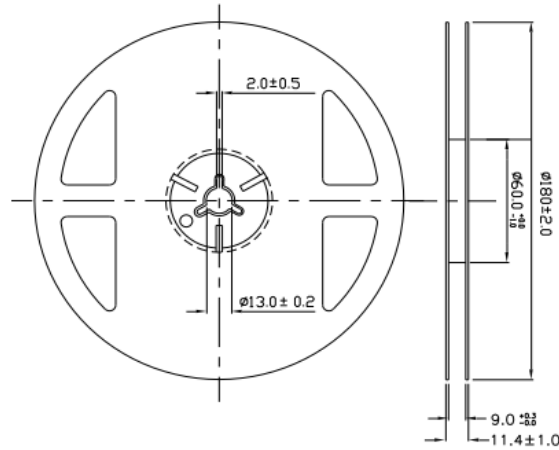

Note: The tolerances unless mentioned is $\pm 0.1\text{mm}$,Unit = mm

Carrier Tape Dimensions:(Quantity: 3000pcs/reel)

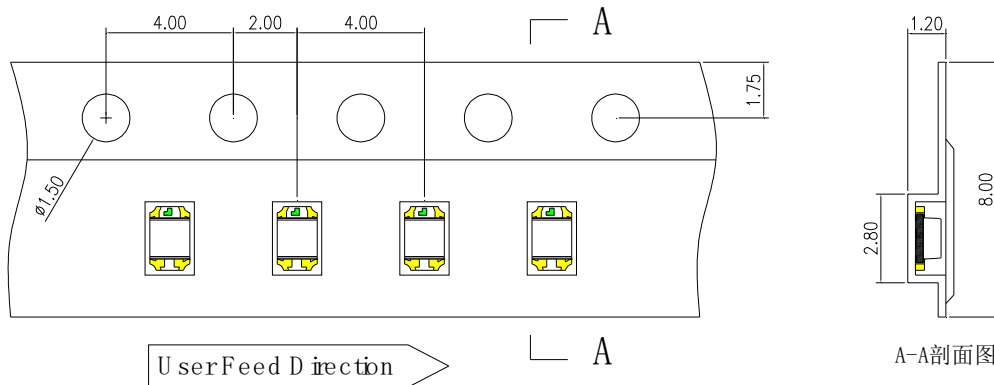

Note:

- 1.Tolerance unless mentioned is $\pm 0.1\text{mm}$,Unit = mm.
- 2.Minimum packing amount is 1000/2000 pcs per reel.

Moisture Resistant Packing Process

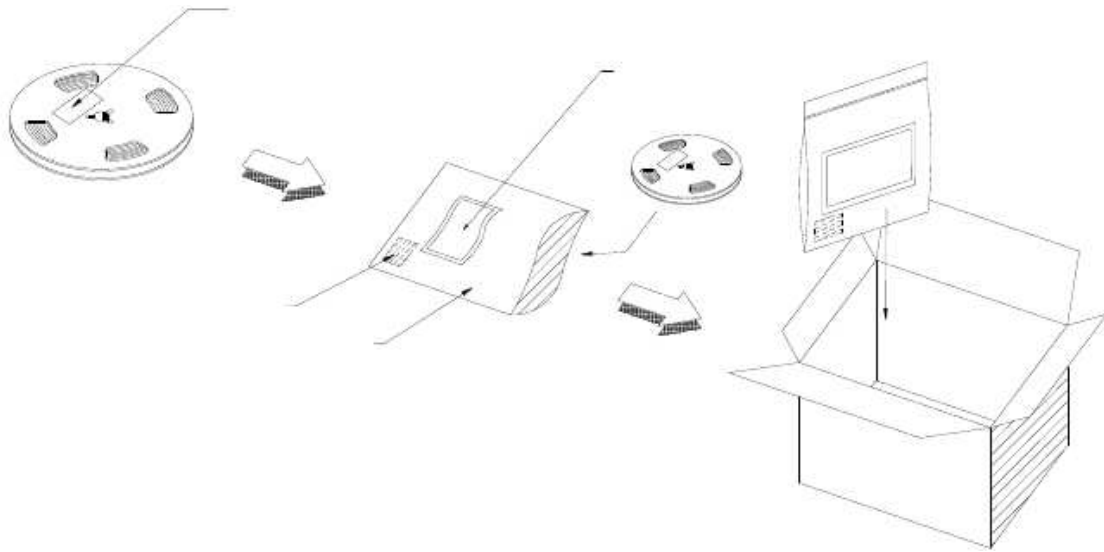

Reliability Test Items and Conditions

The reliability of products shall be satisfied with items listed below.

Confidence level: 90%

LTPD: 10%

No.	Items	Test Condition	Test Hours/Cycles	Sample Size	Ac/Re
1	Reflow Soldering	Temp. : 260°C/10sec.	6 Min	22 PCS	0/1
2	Thermal Shock	H : +100°C 5min ∫ 10 sec L : -10°C 5min	300 Cycles	22 PCS	0/1
3	Temperature Cycle	H : +100°C 15min ∫ 5 min L : -40°C 15min	300 Cycles	22 PCS	0/1
4	High Temperature/Humidity Reverse Bias	Ta=85°C,85%RH	1000 Hrs.	22 PCS	0/1
5	Low Temperature Storage	Ta=-40°C	1000 Hrs.	22 PCS	0/1
6	High Temperature Storage	Ta=100°C	1000 Hrs.	22 PCS	0/1
7	DC Operation Life	Ta=25°C IF = 20 mA	1000 Hrs.	22 PCS	0/1

Precautions For Use

1. Over-current-proof

Customer must apply resistors for protection , otherwise slight voltage shift will cause big current change (Burn out will happen).

2. Storage

2.1 Do not open moisture proof bag before the products are ready to use.

2.2 Before opening the package, the LEDs should be kept at 40°C or less and 90%RH or less.

2.3 The LEDs should be used within a year.

2.4 After opening the package, the LEDs should be kept at 30°C or less and ϵ less.

2.5 The LEDs should be used within 168 hours (7 days) after opening the package

2.6 If the moisture absorbent material (silica gel) has faded away or the LEDs have exceeded the storage time, baking treatment should be performed using the following J-STD-33 Standard.

3. Soldering Condition

3.1 Pb-free solder temperature profile

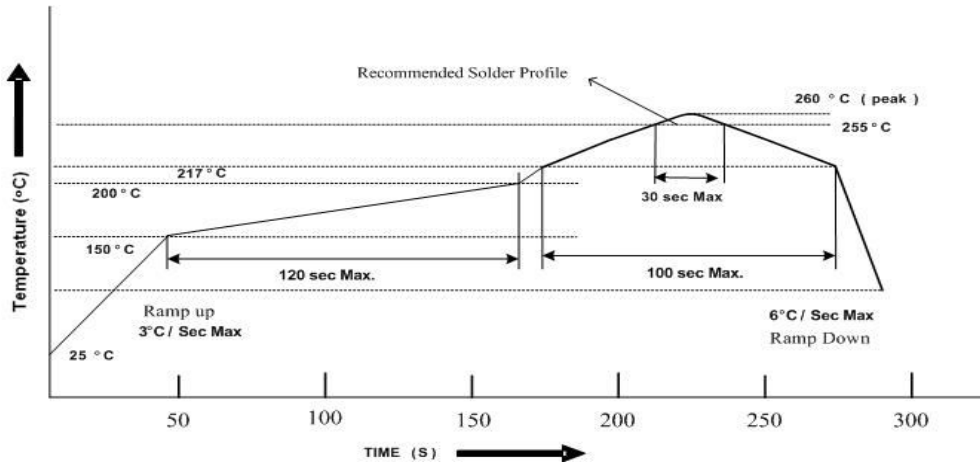

3.2 Reflow soldering should not be done more than two times.

3.3 When soldering, do not put stress on the LEDs during heating.

3.4 After soldering, do not warp the circuit board.

4. Soldering Iron

Each terminal is to go to the tip of soldering iron temperature less than 350°C for 3 seconds within once in less than the soldering iron capacity 25W. Leave two seconds and more intervals, and do soldering of each terminal. Be careful because the damage of the product is often started at the time of the hand solder.

5. Repairing

Repair should not be done after the LEDs have been soldered. When repairing is unavoidable, a double-head soldering iron should be used (as below figure). It should be confirmed beforehand whether the characteristics of the LEDs will or will not be damaged by repairing.