



# Date Sheet

---

Customer: \_\_\_\_\_

Part No: CL-SFC281UHY-B-02(0.5W)

Sample No: \_\_\_\_\_

Description: \_\_\_\_\_

Item No: \_\_\_\_\_

Customer			
Check	Inspection	Approval	Date

## Features

- Package Size: 2.8(L) ×3.5(W) ×0.8(T)mm
- Silicone Packed
- Suitable for different working environment
- Super long lifetime: 50000HRs
- Anti UV
- White colors are available in(2300K- 25000K)
- Wide viewing angle ( $2\theta$  1/2 =120 ° )

## Applications

- Indoor lighting: Fluorescent lamp, tube
- Commercial illumination and displays: Advertising words, light box
- LCD Backlighting
- Decorative lighting: light strip
- Automotive interior auxiliary lighting
- Other illumination and displays

## Device Selection Guide

ITEM	MATERIALS
Resin	Silicon
Bonding wire	25 Em Au
Lens color	Water Clear
Dice	AlGaInP

REFLECTOR COATING TYPE HIGH-PERFORMANCE LEDs

High Performance SMD Single-Color Top LEDs

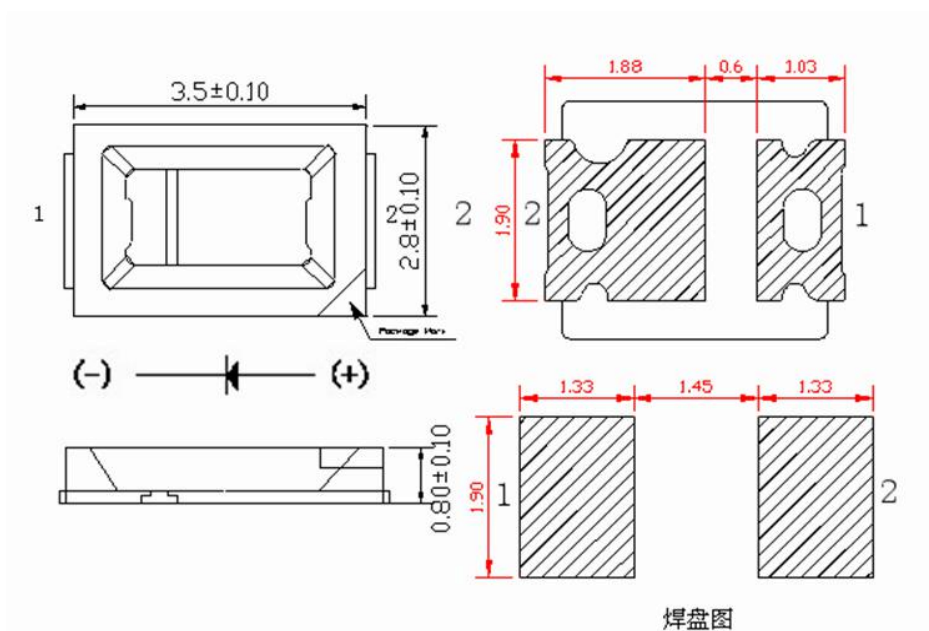

NOTES:

- 1、 All dimensions are in millimeters (inches);
- 2、 Tolerances are  $0.2\text{mm}$  ( $0.008\text{inch}$ ) unless otherwise noted

**Absolute maximum ratings**
**(TA=25°C)**

Paramete	Symbol	Rat	Unit
Forward current	I F	150	mA
Reverse voltage	VR	5	V
Power dissipation	Pd	0.5	W
Operating Temperature	TOP	-20 ~+80	°C
Storage Temperature	Tstg	-40 ~+80	°C
Peak Forward Current ( Duty 1/10 @ 1KHz)	IFP	300	mA
Lead Soldering Temperature (5mm From Body)	TSOI	260°C For 5 Seconds)/°C	

**Electro-optical characteristics**
**(T A =25°C)**

Parameter	Test Condition	Symbo	Value			Unit
			Min	Avg	Max	
CIE Coordinates	I F =150mA	X				
		Y				
Forward voltage	I F =150mA	Vf	1.8	2.0	2.2	V
Wavelength	I F =150mA	nm	590	592	595	nm
Luminous Flux	I F =150mA	φ	7	9	12	Lm
Luminous intensity	I F =150mA	Iv				mcd
Viewing Angle	////////	2θ1/2	////////	120	////////	deg
Reverse Current	////////	IR	////////	////	10	EA

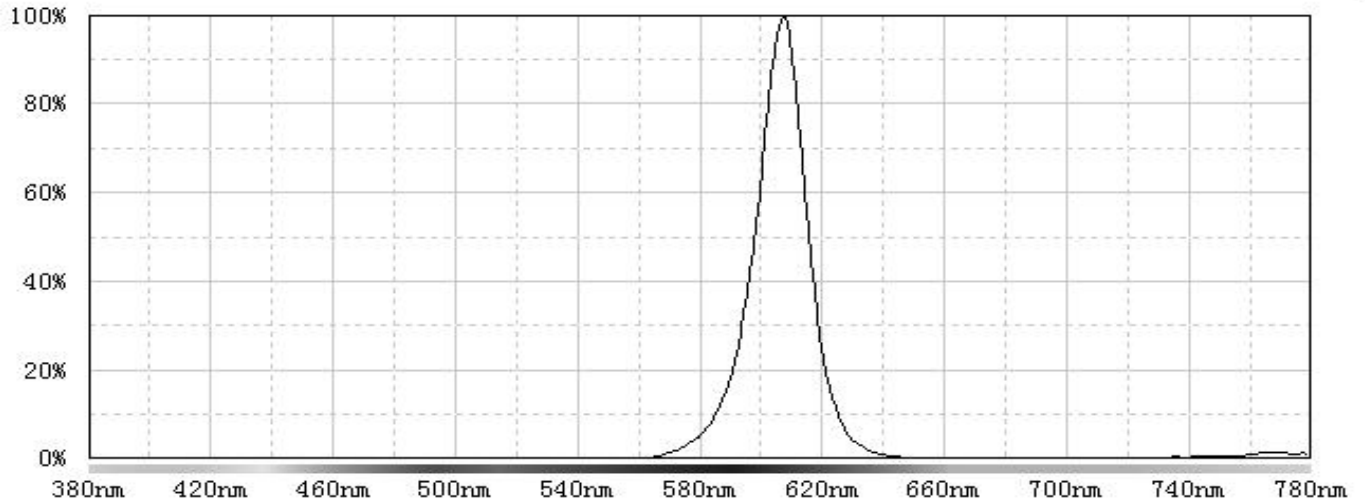
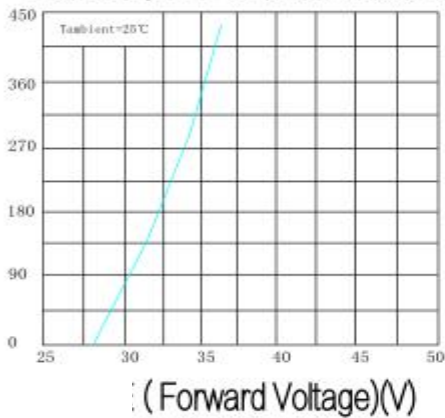
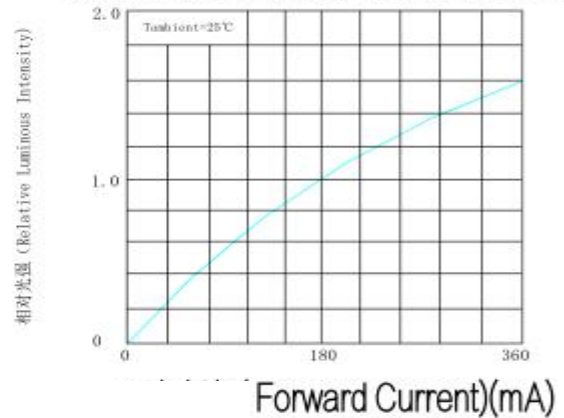
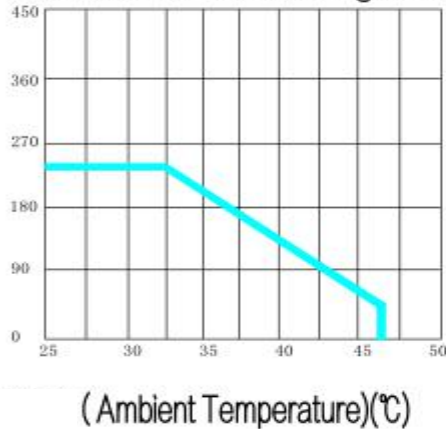
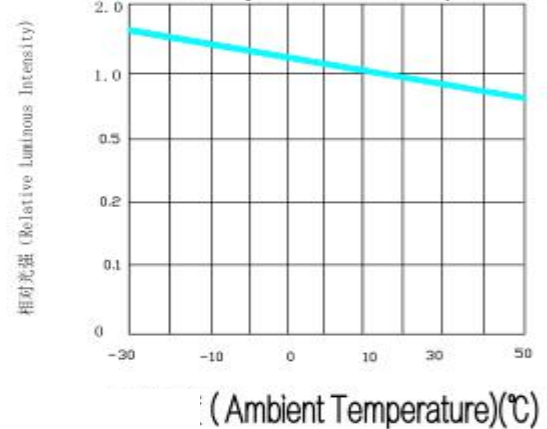
**相对光谱功率**

**(Optical-Electrical Characteristic)**
**Volt-Ampere Characteristics**

**Relative Luminous Intensity VS Forward Current**

**Forward Current Derating Curve**

**Luminous Intensity VS Ambient Temperature**

## Test items and results of reliability

Type	Test item	Standard	Test Conditions	Note	Quantity	Number of Damaged
Environmental Sequence	Temperature Cycle	JIS C 7021 (1977)A-4	-25°C 30min ↑↓5min 80°C 30min	100 cycle	22	0
	Thermal Shock	MIL-SLD-107D	-25°C 15min ↑↓5min 80°C 15min	50 cycle	22	0
	High Humidity Heat Cycle	JIS C 7021 (1977)A-5	30°C <=> 65°C 90%RH 24hrs/1cycle	10 cycle	22	0
	High Temperature Storage	JIS C 7021 (1977)B-10	T <sub>a</sub> =80°C	1000hrs	22	0
	Humidity Heat Storage	JIS C 7021 (1977)B-11	T <sub>a</sub> =60°C RH=90%	1000hrs	22	0
	Low Temperature Storage	JIS C 7021 (1977)B-12	T <sub>a</sub> =-30°C	1000hrs	22	0
Operation Sequence	Life Test	JIS C 7035 (1985)	T <sub>a</sub> =25°C I <sub>F</sub> =60mA	1000hrs	22	0
	High Humidity Heat Life Test	①	60°C RH=90% I <sub>F</sub> =60mA	500hrs	22	0
	Low Temperature Life Test	①	T <sub>a</sub> =-25°C I <sub>F</sub> =60mA	1000hrs	22	0

Refer to reliability test standard specification for in this line.

## Criteria For Judging Damage

Item	Symbol	Test Conditions	Criteria For Judgment
Forward Voltage	V <sub>F</sub>	I <sub>F</sub> =I <sub>FT</sub>	Initial Data±10%
Reverse Current	I <sub>R</sub>	V <sub>R</sub> =5V	I <sub>R</sub> ≦ 10μA
Luminous Intensity	I <sub>V</sub>	I <sub>F</sub> =I <sub>FT</sub>	Average I <sub>v</sub> degradation ≦ 30% Single LED I <sub>v</sub> degradation ≦ 50%
Resistance to Soldering Heat	--	--	Material without internal cracks, no material between stripped, no deaded light.

The technical information shown in the data sheets are limited to the typical characteristics and circuit examples of the referenced products. It does not constitute the warranting of industrial property nor the granting of any license.

(Useful hint) :

### 1、 Hand Soldering

A soldering iron of less than 20W is recommended to be used in Hand Soldering. Please keep the temperature of the soldering iron under  $360^{\circ}\text{C}$  while soldering. Each terminal of the LED is to go for less than 3 seconds and for one time only.

Be careful because the damage of the product is often started at the time of the hand soldering.

2. Reflow Soldering: Use the conditions shown in the under Figure of Pb-Free Reflow Soldering

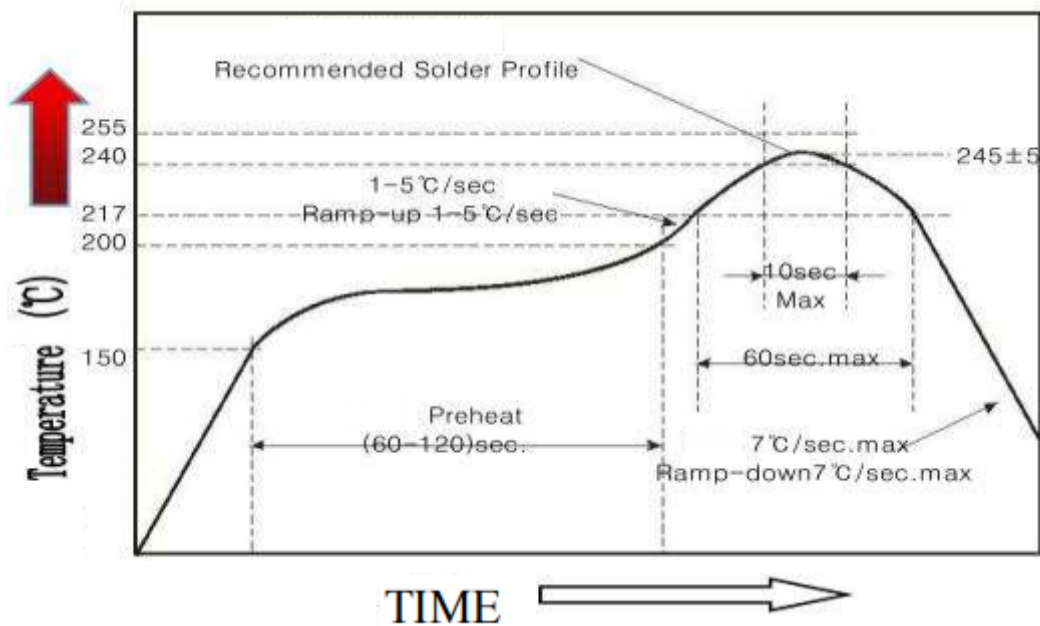

- Reflow soldering only allowed to do once
- Stress on the LEDs should be avoided during heating in soldering process
- After soldering, do not deal with the product before its temperature drops down to room temperature.

## Precautions(1)

### 1. Storage

Moisture proof and anti-electrostatic package with moisture absorbent material is used, to keep moisture to a minimum.

● Before opening the package, the product should be kept at 30°C or less and humidity less than 60% RH, and be used within a year.

● After opening the package, the product should be stored at 30°C or less and humidity less than 10%RH, and be soldered within 24 hours (1day). It is recommended that the product be operated at the workshop condition of 30°C or less and humidity less than 60%RH.

● If the moisture absorbent material has faded away or the LEDs have exceeded the storage time, baking treatment should be performed based on the following condition:  $(70 \pm 5)^{\circ}\text{C}$  for 24 hours

### 2. Static Electricity

Static electricity or surge voltage damages the LEDs. Damaged LEDs will show some unusual characteristics such as the forward voltage becoming lower, or the LEDs do not light at the low current, even not light.

All devices, equipment and machinery must be properly grounded. At the same time, it is recommended that wrist bands or anti-electrostatic gloves, anti-electrostatic containers be used when dealing with the LEDs.



## Precautions (2)

### 3. Vulcanization

**LED curing is due to sulfur being in bracket and the +1 price of silver in the chemical reaction generated  $\text{Ag}_2\text{S}$  in the process. It will lead to the capacity of reflecting of silver layer reducing, light color temperature drift and serious decline ,seriously affecting the performance of the product. So we should take corresponding measures to avioding vulcanization, such as to avoid using sulphur volatile substances and keeping away from high sulphur content of the material.**

### 4. Safety Advice For Human Eyes

**Viewing direct to the light emitting center of the LEDs, especially those of great Luminous Intensity will cause great hazard to human eyes. Please be careful.**