

# Data Sheet

---

Customer: C1A001151

Part No: CL-SF685RIR-660,940-01

Sample No: \_\_\_\_\_

Description: 3528 Red/IR SMD

Item No: \_\_\_\_\_

Customer			
Check	Inspection	Approval	Date

CL			
Drawn	Check	Approval	Date
			2022/12/8

---

**Features:**

- . Reflow Solderable
- . High Luminous Intensity and Low Power Dissipation
- . Good Reliability and Long Life
- . Complied With RoHS Directive



**Applications**

- Optical indicator
- Indoor display
- Backlighting in dashboard and switch
- Flat backlighting for LCD, symbol and display
- General use

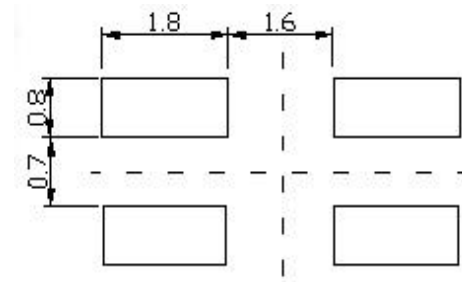
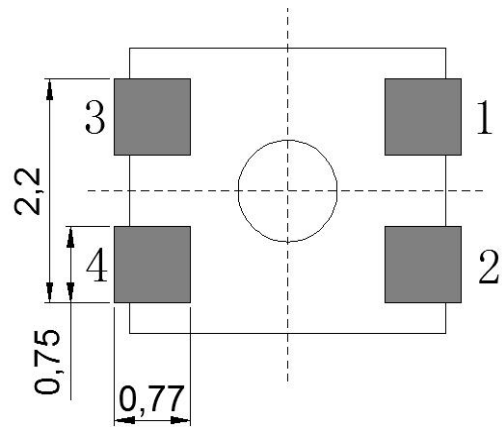
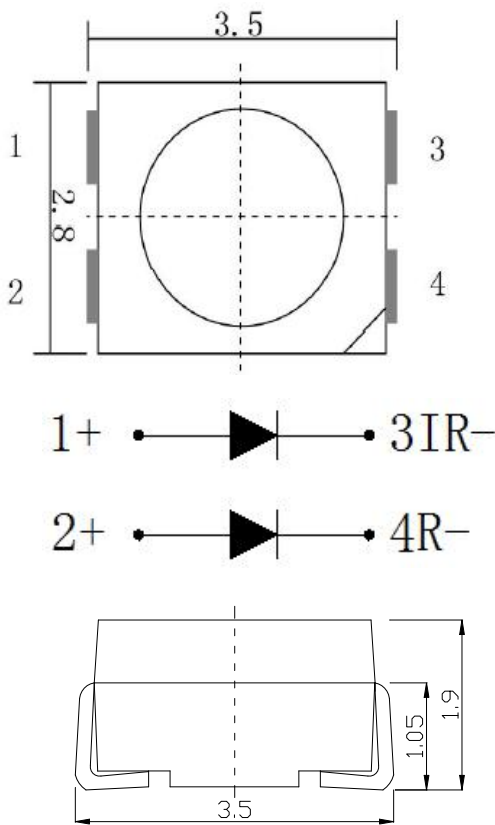

**Notes:**

1. All dimension units are millimeters.
2. All dimension tolerance is  $\pm 0.2\text{mm}$  unless otherwise noted.

### Selection Guide

Part No.	Emitting Color	Lens Type	Luminous intensity(mcd) @ 20mA			Viewing
			Min	Typ	Max	2θ1/2
CL-SF685RIR-660, 940-01	Red	Water Clear	210	--	460	120
			<b>Radiant Intensity(mW/sr)</b>			
	IR		1	--	5	

Note:

- 1.1/2 is the angle from optical centerline where the luminous intensity is 1/2 the optical centerline value.
- 2.the above luminous intensity measurement allowance tolerance ±10%

### Electrical / Optical Characteristics at Ta=25°C

Parameter	Symbol	Min.	Typ.	Max.	Units	test conditions
Forward Voltage	R	1.8	--	2.4	V	IF=20mA
	IR	1	--	1.8		
Reverse Current	IR	--	--	10	uA	VR = 5V
Peak Wavelength	R	--	660	--	nm	IF=20mA
	IR	--	940	--		

### Absolute Maximum Ratings at Ta=25°C

Parameter	Symbol	Rating	Units
Power Dissipation	R	48	mW
	IR	36	
DC Forward Current	IF	20	mA
Peak Forward Current [1]	R	75	mA
	IR	75	
Reverse Voltage	VR	5	V
Electrostatic Discharge (HBM)	ESD	2000	V
Operating Temperature	Topr	-40~+85	°C
Storage Temperature	Tstg	-40~+100	°C

Note:

1. 1/10 Dut cycle,0.1ms pulse width.
2. The above forward voltage measurement allowance tolerance ±0.1V.
3. The tolerance of wave length:±1nm.

### Typical optical characteristics curves

Ambient Temperature VS. Forward Current

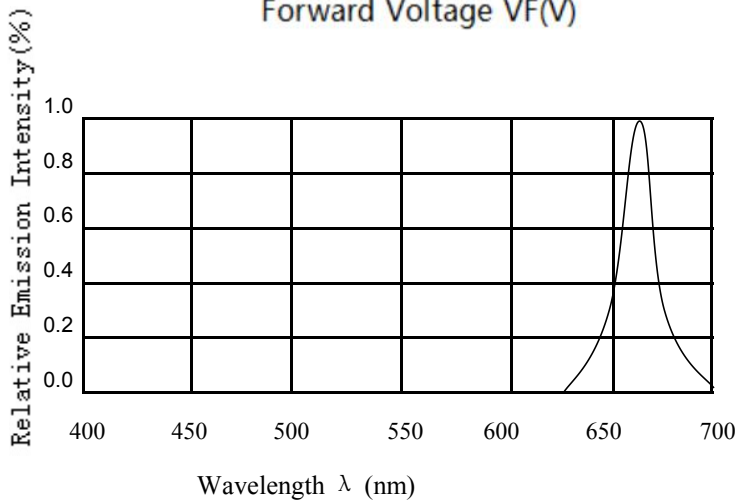
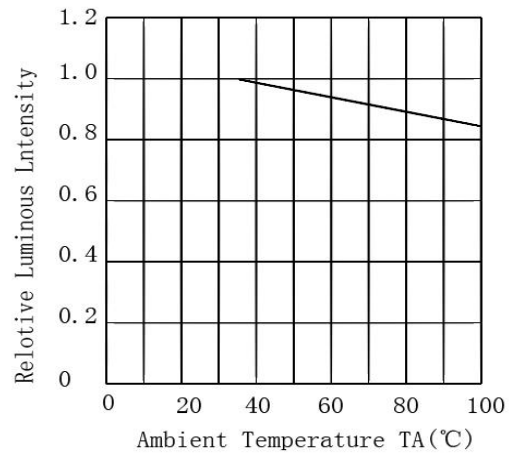
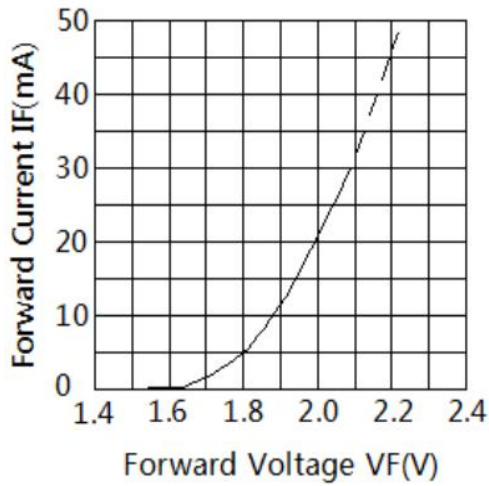
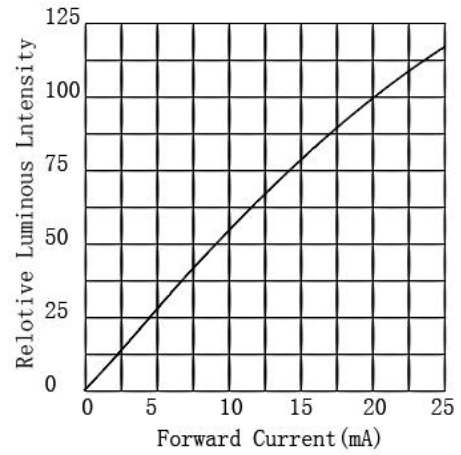
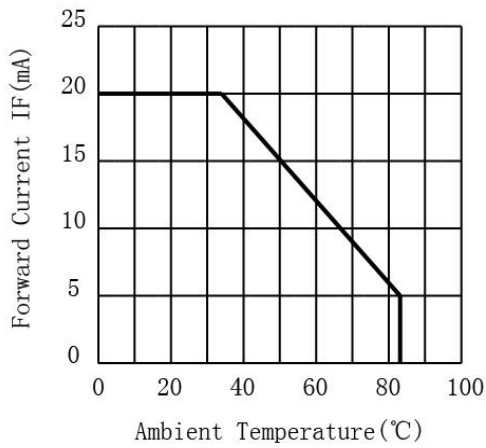

Radiation Diagram  $T_a=25^\circ\text{C}$

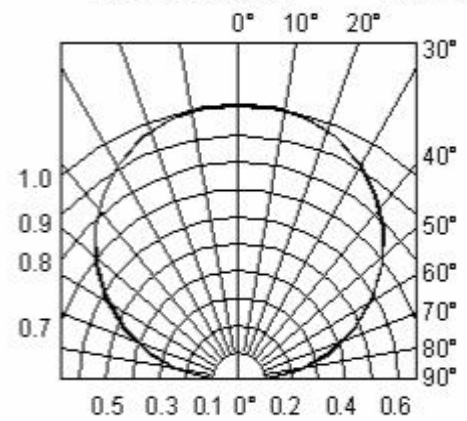

**Typical Optical-Electrical Characteristic Curves**

Fig.1 Forward Current Vs Forward Voltage

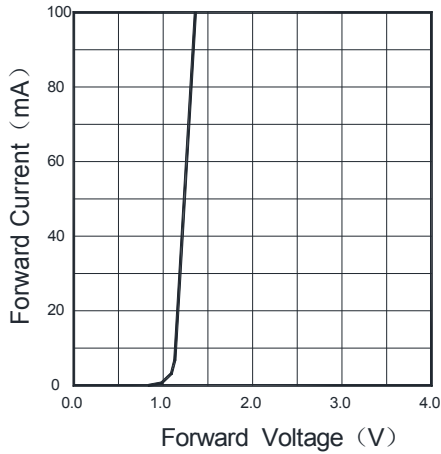

Fig.2 Relative Radiant Intensity Vs Forward Current

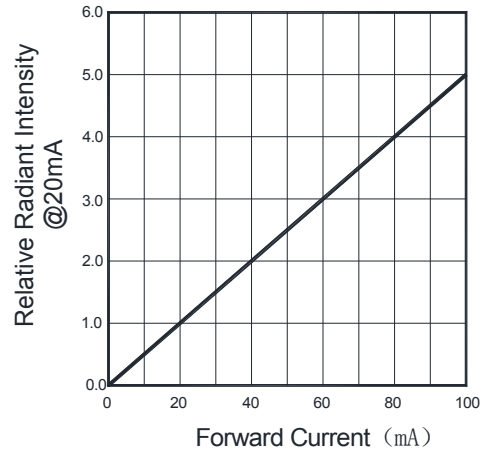

Fig.3 Relative Forward Voltage Vs Ambient Temperature

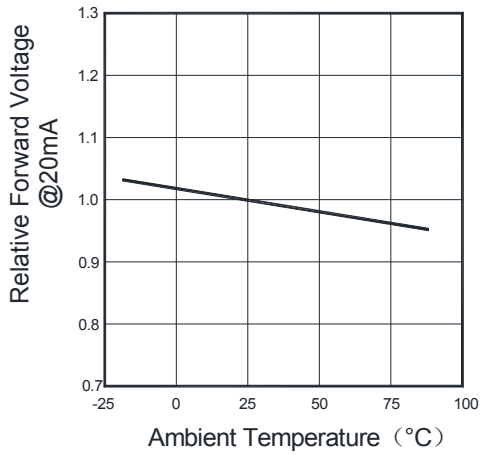

Fig.4 Relative Radiant Intensity Vs Ambient Temperature

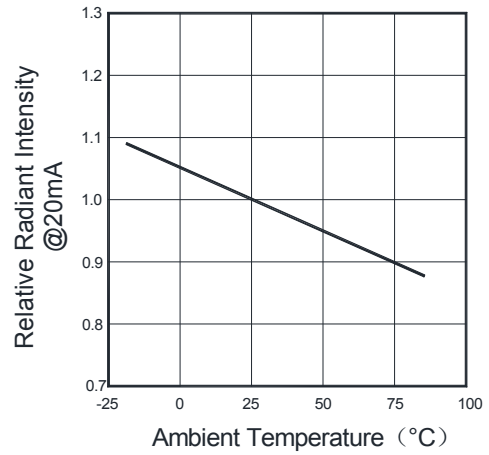

Fig.5 Spectral Distribution

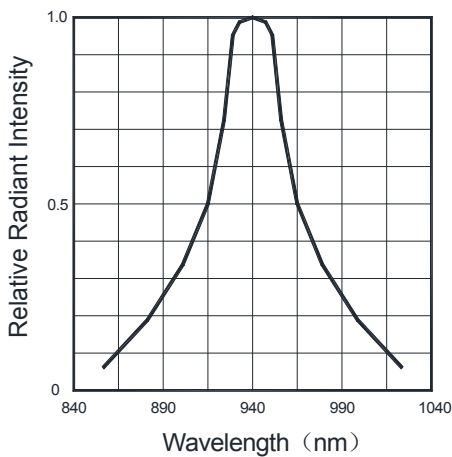
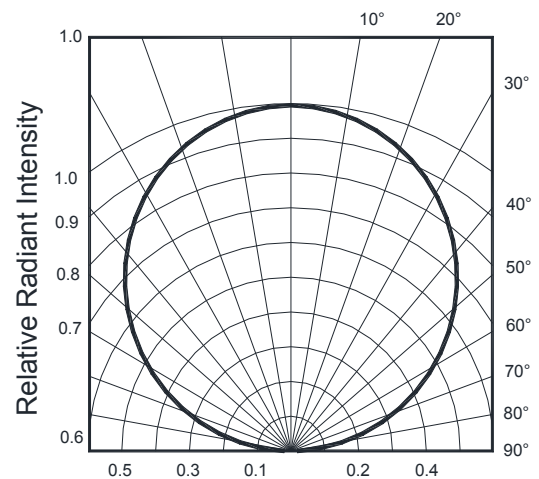

Fig.6 Radiant Diagram



### Reliability Test Items And Conditions

Test Items	Ref.Standard	Test conditions	Time	Quantity	Ac/Re
Reflow Soldering	JESD22-B106	Temp.:260°C±5°C Min.5sec.	3 times.	22Pcs.	0/1
Temperature Cycle	JESD22-A104	100°C±5°C 30 min. ↑↓5 min -40°C±5°C 30 min.	100 Cycles	22Pcs.	0/1
High Temperature Storage	JESD22-A103	Temp:100°C±5°C	1000Hrs	22Pcs.	0/1
Low Temperature Storage	JESD22-A119	Temp:-40°C±5°C	1000Hrs	22Pcs.	0/1
Life Test	JESD22-A108	Ta=25°C±5°C IF=20mA	1000Hrs	22Pcs.	0/1
High temperature and high humidity storage experiment	JESD22-A101	85°C±5°C/ 85%RH	1000Hrs	22Pcs.	0/1

### Criteria For Judging Damage

Test Items	Symbol	Test conditions	Criteria For Judgement	
			Min.	Max.
Forward Voltage	VF	IF=20mA		U.S.L*)x1.1
Reverse Current	IR	VR = 5V		U.S.L*)x2.0
Luminous intensity	IV	IF=20mA	L.S.L*)x0.7	

U.S.L: Upper standard level      L.S.L: Lower standard level

The technical information shown in the data sheets are limited to the typical characteristics and circuit examples of the referenced products.It does not constitute the warranting of industrial property nor the granting of any license.

### SMT Reflow Soldering Instructions

1. The number of reflow soldering shall not exceed two times, and the time from the second processing to the first completion shall not exceed 24H
2. When soldering, do not put stress on the LEDs during heating.
3. Reflow temperature distribution (Acc.to J-STD-020D)

Profile Feature	Sn-Pb Eutectic Assembly		Pb-Free Assembly	
	Large Body	Small Body	Large Body	Small Body
Average ramp-up rate (TL to Tp)	3°C/second max.		3°C/second max.	
Preheat				
-Temperature Min(TSmin)	100°C		150°C	
-Temperature Max(TSmax)	150°C		200°C	
-Time(min to max)(ts)	60-120 seconds		60-180 seconds	
Tsmax to TL				
-Ramp-up Rate			3°C/second max.	
Time maintained above:				
-Temperature(TL)	183°C		217°C	
-Time(tL)	60-150 seconds		60-150 seconds	
Peak Temperature(Tp)	225+0/-5°C	240+0/-5°C	245+0/-5°C	260+0/-5°C
Time within 5°C of actual Peak Temperature(tp)	10-30 seconds	10-30 seconds	10-30 seconds	20-40 seconds
Ramp-down Rate	6°C/second max.		6°C/second max.	
Time 25°C to Peak Temperatur	6 minutes max.		8 minutes max.	

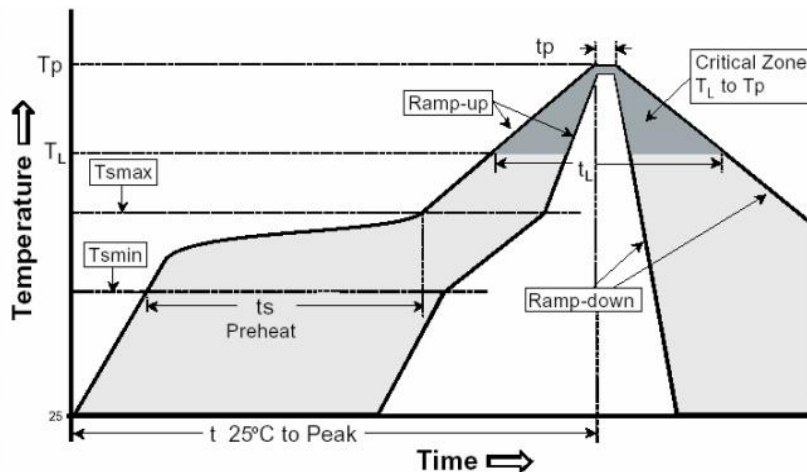

### Soldering iron

1. When hand soldering, the temperature of the iron must be less than 350°C for 3 seconds
2. The hand solder should be done only one time

### Repairing

Repair should not be done after the LEDs have been soldered. When repairing is unavoidable, a double-head soldering iron should be used (as below figure). It should be confirmed in advance whether the characteristics of LEDs will or will not be damaged by repairing.

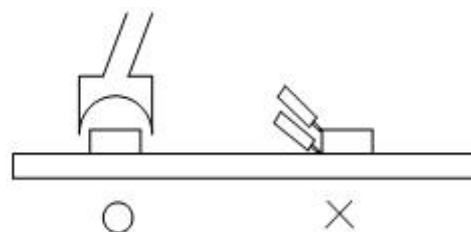

## Storage

This product uses sealing anti-moisture antistatic packaging, and with desiccant, humidity card.

Before packaging is opened:

1、 Storage environment: the ambient temperature should be kept between 5°C and 30°C, and the relative humidity should be kept within 60% RH. When the storage time of the product exceeds 3 months, it must be dehumidified before use. The dehumidification condition is: 65°C/24H.

2、 Please check that the package is leaking before opening. If it has leaked, please re-bake and use it or return to the plant to dehumidify.

After opening the package:

1、 After opening the package, check whether the humidity card has a discoloration phenomenon. For example, 20 % of the humidity card indicates discoloration. Please remove the material from the bag and use it after dehumidifying 24H at 65 °C.

2、 Environmental conditions: The ambient temperature should be kept between  $\leq 30^{\circ} \text{C}$  and relative humidity The lower 60 % RH should be maintained.

3、 if the material is not produced after exposure in the workshop for more than 24 hours, the product must be put back in the oven, dehumidified with 65 °C 24H, and then can be used again. If the material is not produced after 48 hours of exposure in the workshop, return the material to the SMD plant for high temperature dehumidification.

4、 When the material is dehumidified, please do not open the oven in the middle, so that the oven temperature will not drop to the dehumidification effect.

Please refer to the following operating methods when the material needs to be dehumidified



Correct way: material desiccant need to remove the bag, use the way of hanging baked



Wrong way: the material is dehumidified without removing the bag, in a stacking manner



## ESD

Static Electricity will damage the LED.

The following steps can reduce the likelihood of ESD causing product damage

- 1.All productive machinery and test instruments must be electrically grounded.
- 2.Use a conductive wrist band or anti-electostatic glove when handling these LEDs.
- 3.Manintain a humidity level of 50%RH or higher in production areas.
- 4.Use anti-static packaging for transport and storage.

## Handling Precautions

- 1.Do not stack the assembled PCB together. This may scratch the surface of the product or damage the circuit.

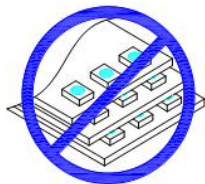

- 2.Not available in the situation of acidity for PH.



- 3.Electrostatic sensitive device



**Carrier tape**

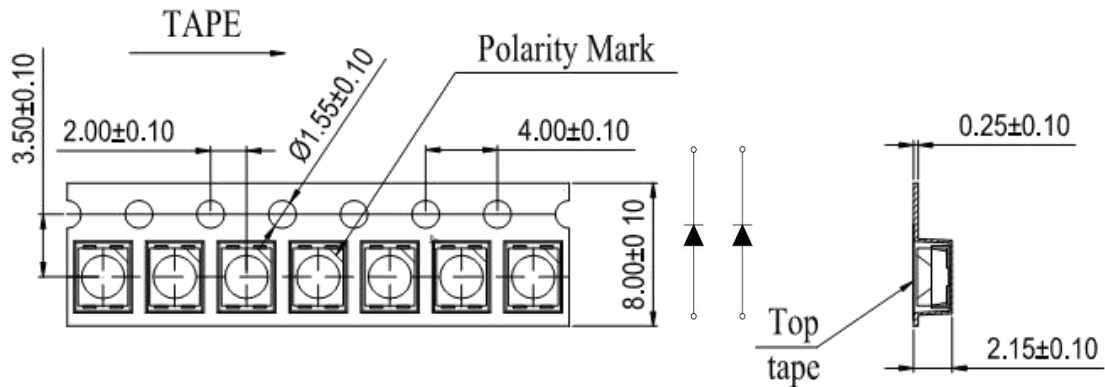

MPQ:2000PCS/Small reel

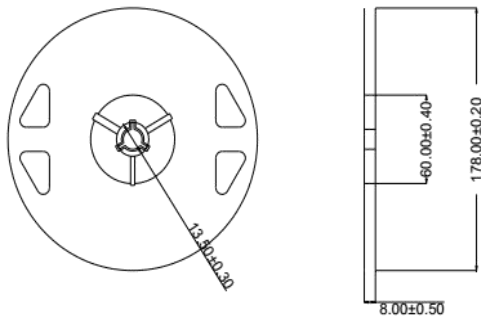

MPQ:10000PCS/Big reel

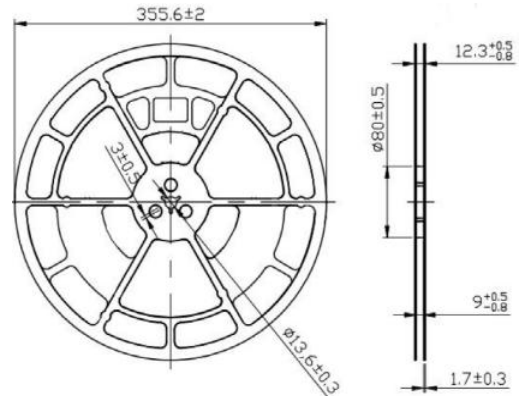

**Moisture Resistant Packaging**

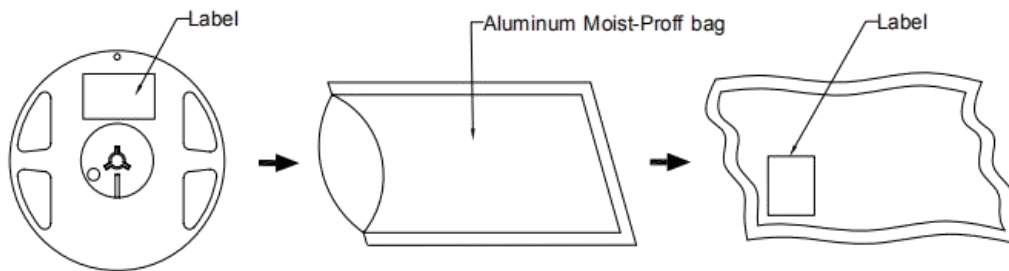

**Cardboard Box**

Maximum packing quantity (5 packs of material)

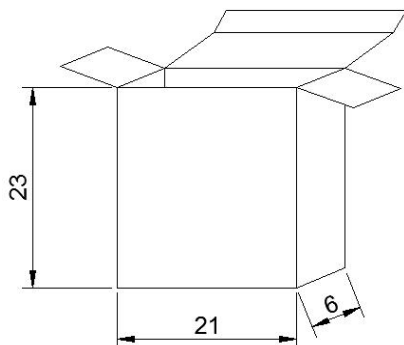

Maximum packing quantity (27 bags of material or 5 small boxes)

