



Data Sheet

Customer: _____

Part No: _____

CL-3014UWC1A-001

Sample No: _____

Description: _____

3Ø Lamp White Color

Item No: _____

Customer			
Check	Inspection	Approval	Date

FEATURES

- Low power consumption.
- High Efficiency
- Round type
- T1(3mm) diameter
- With Flange
- Solder leads without stand-off
- Compliant with RoHS

DESCRIPTIONS

- Chip Material: InGaN
- Emitting Color: Ultra White
- Lens Color: Water Clear

OUTLINE DRAWING

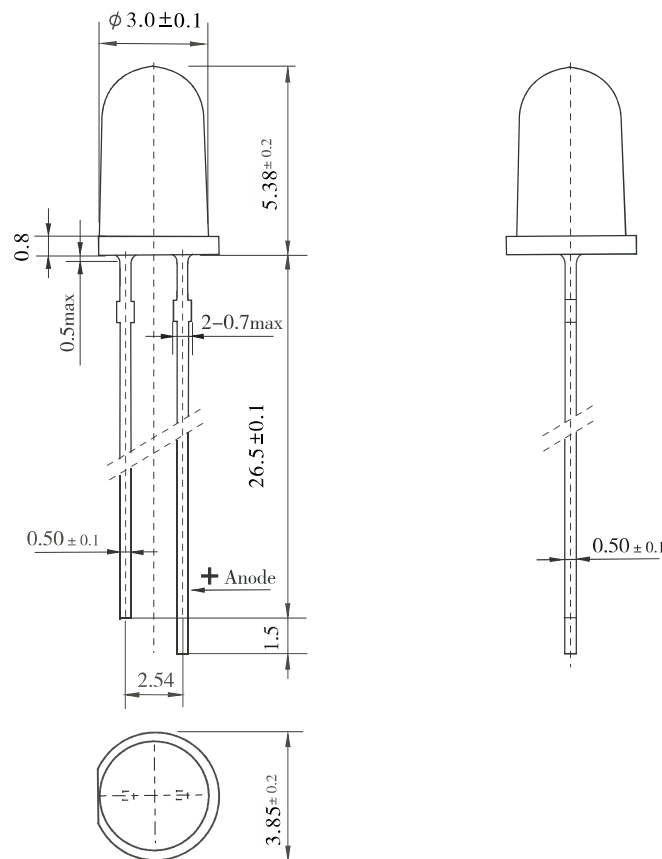

ATTENTION



OBSERVE PRECAUTIONS
FOR HANDLING
ELECTROSTATIC
SENSITIVE DEVICES

Tolerance is $\pm 0.25\text{mm}$
Unless Otherwise Specified.

Electrical Optical Characteristics (Ta=25°C)

Parameter	Symbol	Min	Typ	Max	Unit	Test Condition
Forward Voltage	V _F	---	3.2	3.6	V	IF=20mA
Luminous Intensity	I _V	7000	11000	---	mcd	IF=20mA
Chromaticity Coordinates (Tolerance: ± 0.01)	X	---	0.29	---	nm	IF=20mA
	Y	---	0.29	---	nm	IF=20mA
Spectral Line half-width	Δλ	---	30	---	nm	IF=20mA
Reverse Leakage Current	I _R	---	---	50	μA	VR=5V
Viewing Angle	2 θ _{1/2}	---	30	---	Deg	IF=20mA

Absolute Maximum Parameters (Ta=25°C)

Parameter	Symbol	Condition	Rating	Unit
Power Dissipation	P _D	---	90	mW
Reverse Voltage	V _R	---	5	V
Forward Average Current	I _F	---	25	mA
Temperature coefficient	I/C	---	0.33	mA/ °C
Pulse Current	IFP	Duty=1/10,1kHz	100	mA
Operating Temperature Range	T _{opr}	---	-25 ~ +85	°C
Storage Temperature Range	T _{stg}	---	-30 ~ +100	°C
Soldering Condition	T _{sd}	---	260°C/5sec	°C

NOTE:

Luminous Intensity Measurement allowance is ± 10%.

2 θ_{1/2} is the off-axis angle at which the luminous intensity is half the axial luminous intensity.

The dominant wavelength is derived from the CIE chromaticity diagram and represents the single wavelength which defines the color of the device.

Chromaticity Bin (Ta=25°C)

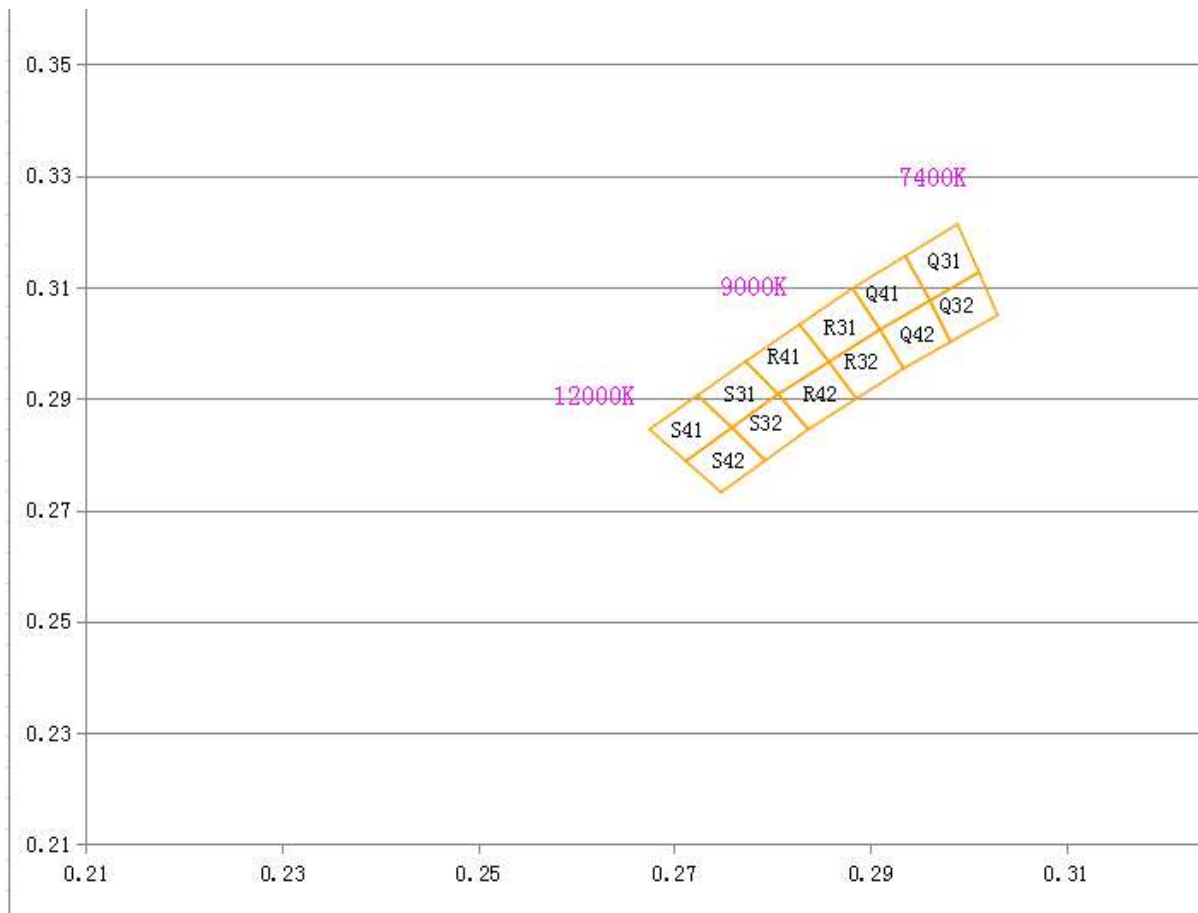

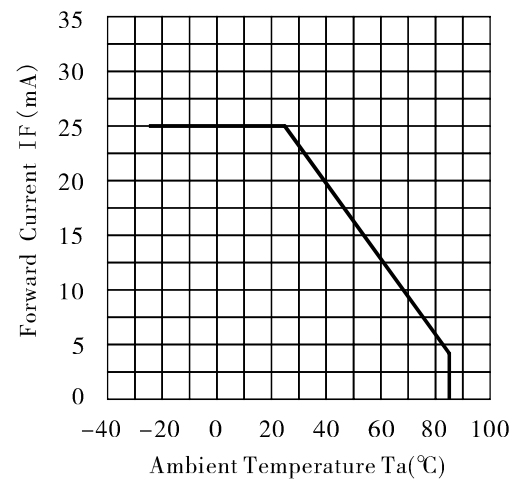
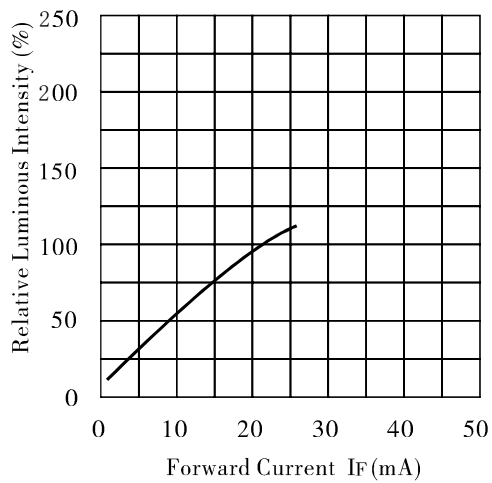
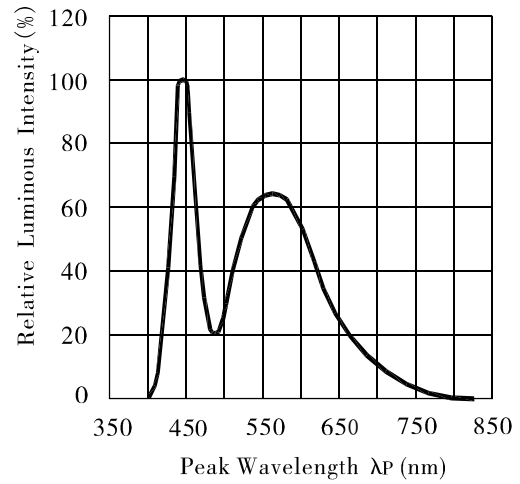
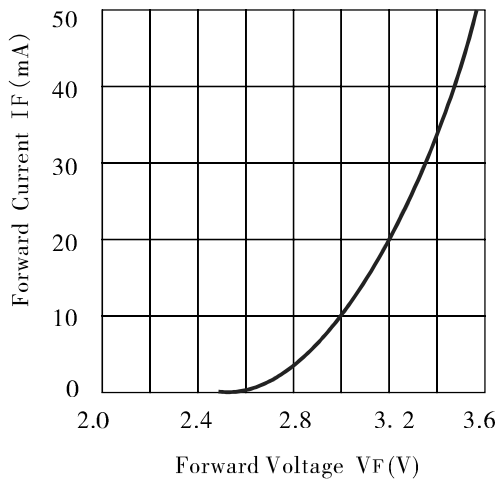
Typical Electro/Optical Characteristic Curves ($T_a=25^\circ\text{C}$)

Directive Characteristics

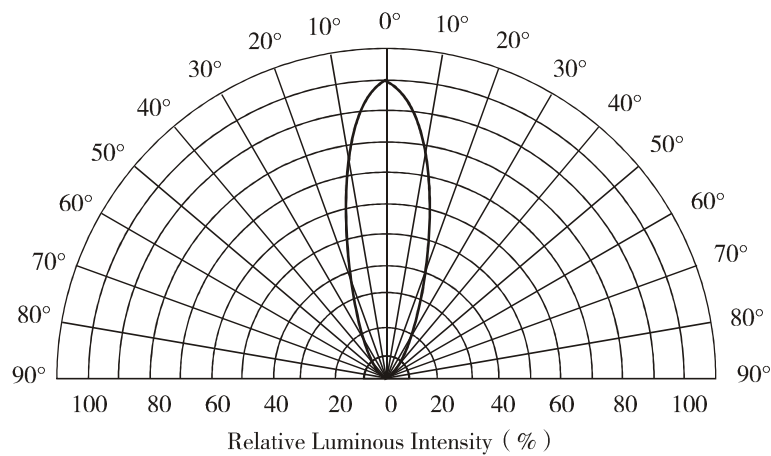

Reliability Test Conditions

Test Item	Test Condition	Result	Judgment Criteria
Consecutive operating life test	IF=20mA, T=25℃, t=168h	0/100	Forward Voltage VF(V)= Upper Limit × 1.2 Reverse Leakage Current IR(μA)=Upper Limit × 2.0 Luminous Intensity IV (mcd)=Lower Limit × 0.7
High temperature storage life test	T=100℃, t=168h	0/100	
Low temperature storage life test	T=25℃, t=168h	0/100	
High temperature humidity storage life test	T=85 ± 2℃, RH=85% ± 3, t=168h	0/100	
Temperature cycle test	-25℃~25℃~100℃ 30min 5min 30min 10cycles	0/100	
Thermal shock test	100℃ 0℃ 5min 5min 20cycles	0/100	
Soldering heat test	T=260 ± 5℃, t=10s ± 1s	0/100	
Solderability test	T=235 ± 5℃, t=5s ± 0.5s	0/100	Steeped Part ≥ 95%
Fall test	h=100cm, 50times	0/100	Surface Appearance Photoelectric Properties Intact
Terminal strength test	W=9.8N, t=30 ± 5s	0/100	
Lead bending test	W=4.9N, 2times	0/100	