



Data Sheet

Customer: _____

Part No: _____

CL-SP192UHYDNB-02

Sample No: _____

Description: _____

1608 SMD Y+B Bi Color

Item No: _____

Customer			
Check	Inspection	Approval	Date



Features

Features

- _1.6mmx0.8mm SMT LED,0.60mm THICKNESS.
- _LOW POWER CONSUMPTION.
- _WIDE VIEWING ANGLE.
- _IDEAL FOR BACKLIGHT AND INDICATOR.
- _VARIOUS COLORS AND LENS TYPES AVAILABLE.
- _PACKAGE : 4000PCS / REEL.
- _RoHS COMPLIANT.

Description

The Blue source color devices are made with GaN on Sapphire Light Emitting Diode.

The Hyper Red source color devices are made with DH InGaAlP on GaAs substrate Light Emitting Diode

Package Dimensions

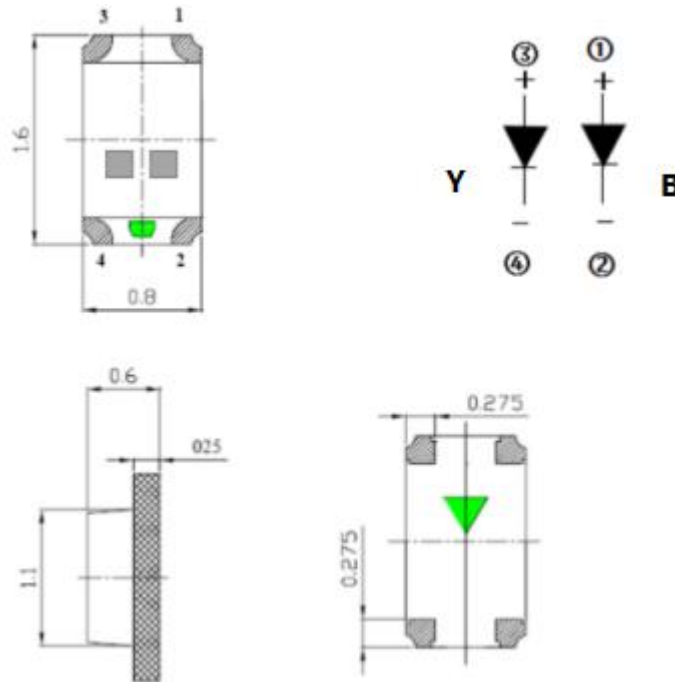

Notes:

1. All dimensions are in millimeters (inches).
2. Tolerance is $\pm 0.1(0.004)$ unless otherwise noted.
3. Specifications are subject to change without notice.

Selection Guide

Part No.	Dice	Lens Type	Iv (mcd) @ 5mA		Viewing Angle
			Min.	Typ.	2 θ 1/2
CL-SP192UHYDNB-02	YELLOW (AlGaInP)	WATER CLEAR	70	150	120
	BLUE (InGaN)		100	160	

Note:

1. θ 1/2 is the angle from optical centerline where the luminous intensity is 1/2 the optical centerline value.

Electrical / Optical Characteristics at TA=25°C

Symbol	Parameter	Device	Typ.	Max.	Units	Test Conditions
λ _{peak}	Peak Wavelength	Blue			nm	IF=20mA
		Yellow				
λ _D	Dominant Wavelength	Blue	460	475	nm	IF=5mA
		Yellow	586	592		
Δλ _{1/2}	Spectral Half-width	Blue	25		nm	IF=20mA
		Yellow	30			
C	Capacitance	Blue	100		pF	VF=0V;f=1MHz
		Yellow	30			
VF	Forward Voltage	Blue	2.8	3.2	V	IF=5mA
		Yellow	1.9	2.1		
IR	Reverse Current	Blue		5	uA	VR = 5V
		Yellow		2		

Absolute Maximum Ratings at TA=25°C

Parameter	Blue	Red	Units
Power dissipation	105	75	mW
DC Forward Current	30	30	mA
Peak Forward Current [1]	135	80	mA
Reverse Voltage	5	5	V
Operating/Storage Temperature	-40°C To +85°C		

Note:

1. 1/10 Duty Cycle, 0.1ms Pulse Width.

Yellow

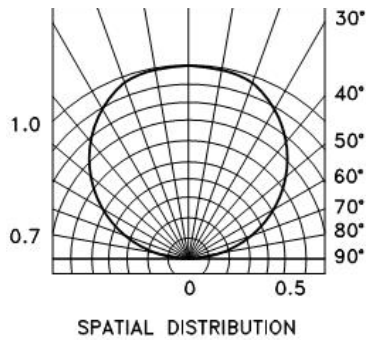
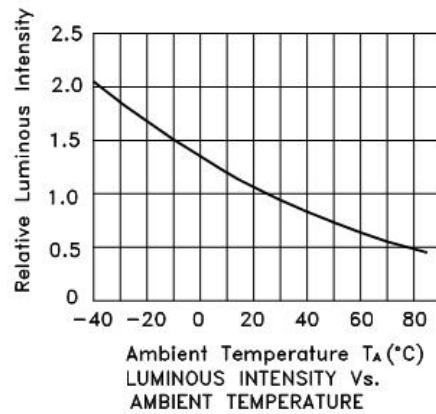
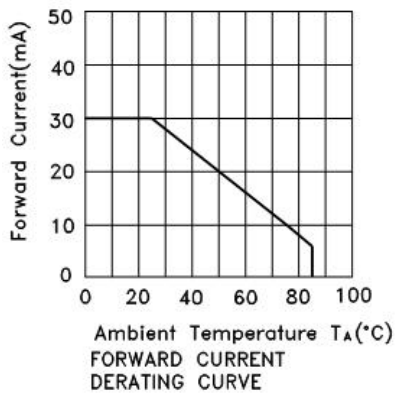
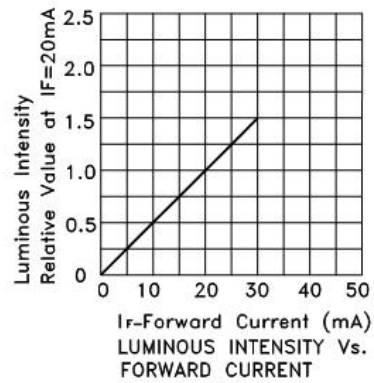
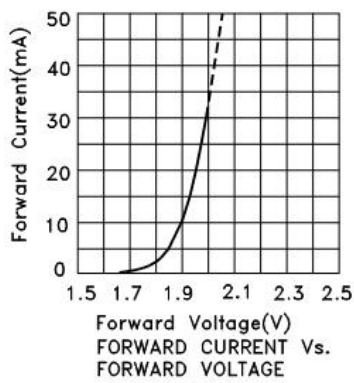
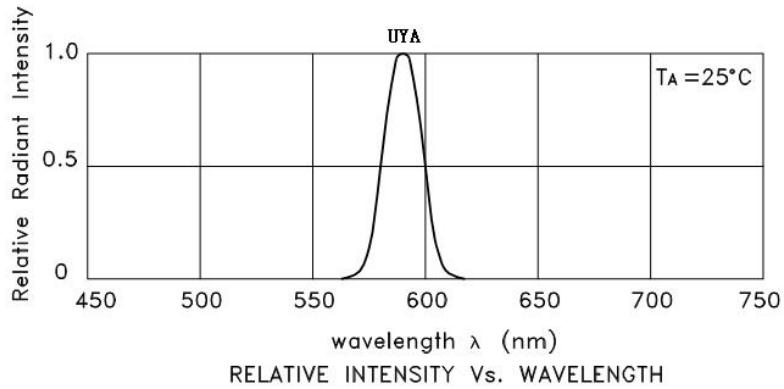

Blue

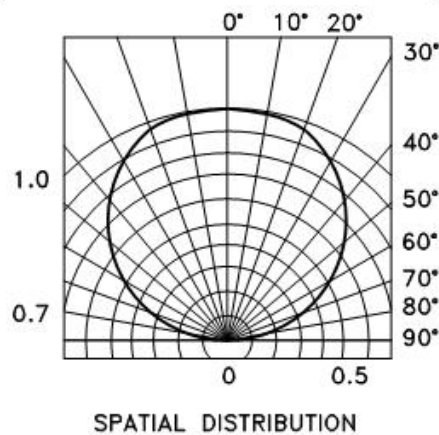
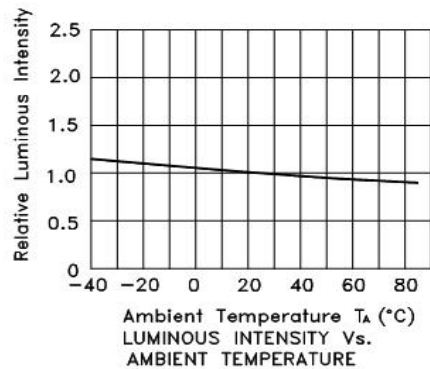
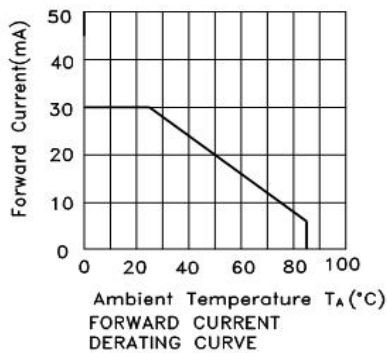
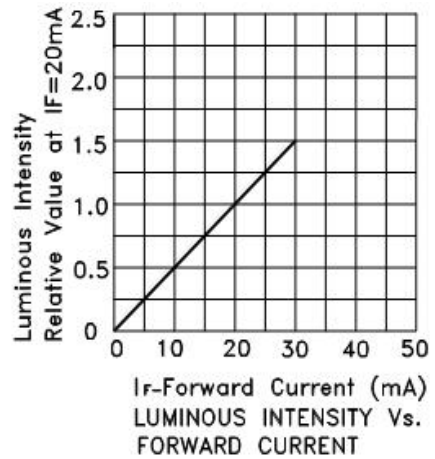
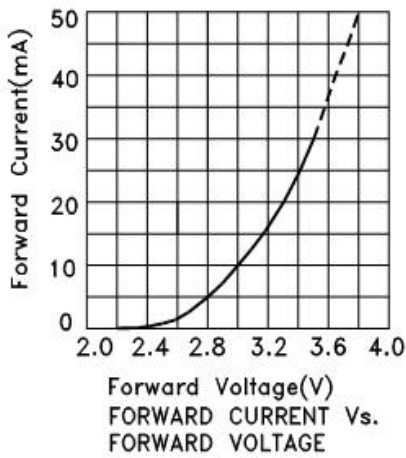
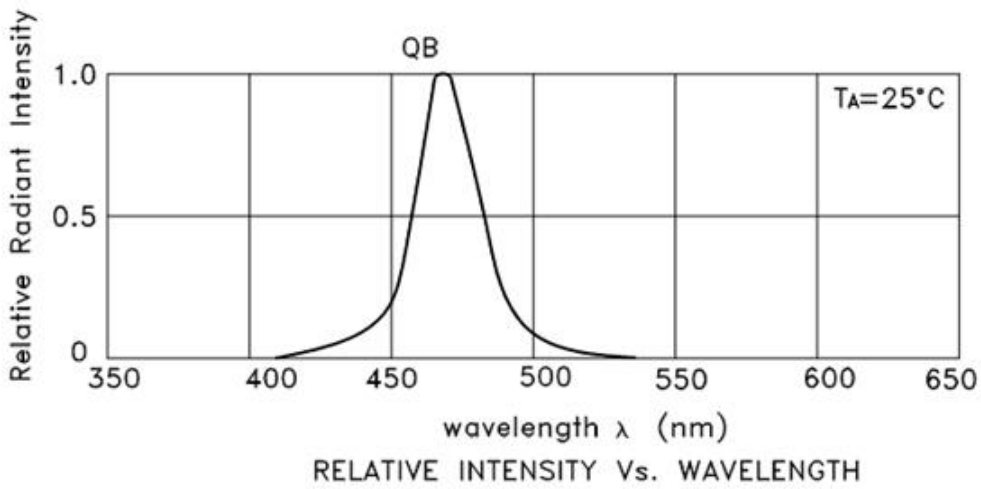

RELIABILITY

Test Items and Results

NO.	Test Item	Reference Standard	Test Conditions	Note (Hours/Cycles)	Sample	Number of Damaged
1	Temperature Cycle	JEITA ED-4701	-40°C ~ 25°C ~ 100°C ~ 25°C 30min 5min 30min 5min	100 Cycles	50	0/50
2	Thermal shock	MIL-STD-202G	-40°C ~ 100°C 15min 15min	500 Cycles	50	0/50
3	High Temperature Storage	JEITA ED-4701 200 201	T _a =100°C	1000 Hours	50	0/50
4	Low Temperature Storage	JEITA ED-4701 200 201	T _a =-40°C	1000 Hours	50	0/50
5	Room Temperature Life Test		T _a =25±5°C I _F =20mA	1000 Hours	50	0/50
6	High Temperature High Humidity Life Test		T _a =60°C RH=85% I _F =20mA	1000 Hours	50	0/50
7	Solderability (Reflow Soldering)	JEITA ED-4701 300 303	T _{sol} =235°C±5°C, 5sec (Using Flux, Lead Solder)	1 time, 5sec	10	0/10
8	Resistance to Soldering Heat (Reflow Soldering)	JEITA ED-4701 300 301	T _{sol} =260°C, 10 sec Pre Treatment: 35°C 95% RH 96 Hrs	2 time, 10sec	10	0/10

Cautions

(1) Soldering Conditions

Number of reflow process shall be less than 2 times and cooling process to normal temperature is required between first and Second soldering process.

(Recommended soldering conditions)

Reflow Soldering			Hand soldering	
	Lead Solder	Lead-free Solder	Temperature	350° C Max.
Pre-heat	140 ~ 160° C	180 ~ 200° C	Soldering	3 sec. Max. (one time only)
Pre-heat time	120 sec. Max.	120 sec. Max.		
Peak temperature	230° C Max.	260° C Max.		
Soldering time	10 sec. Max.	10 sec. Max.		
Condition				

Lead Solder

Lead-Free Solder

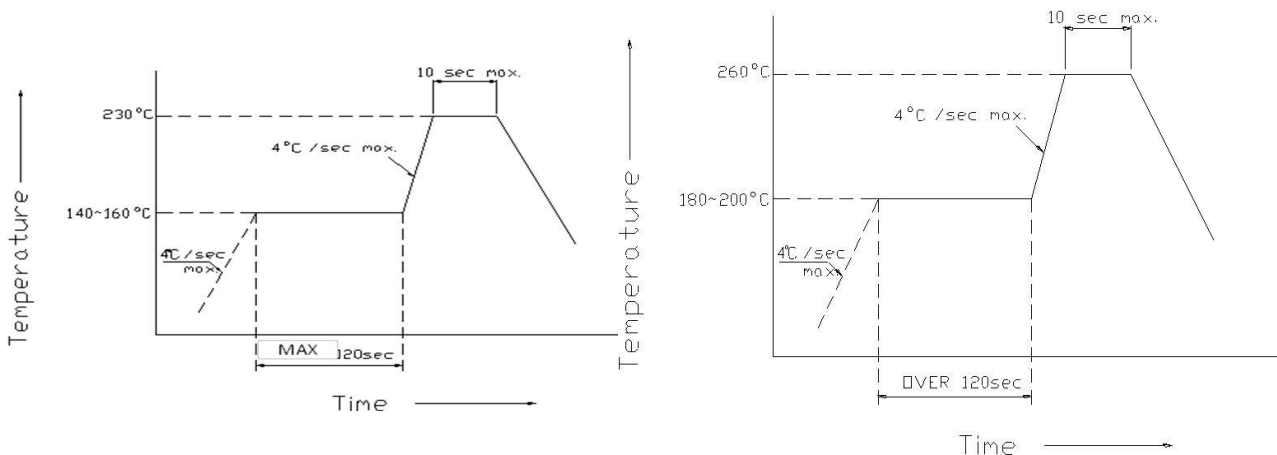

Recommended Soldering Pattern

(Units : mm)

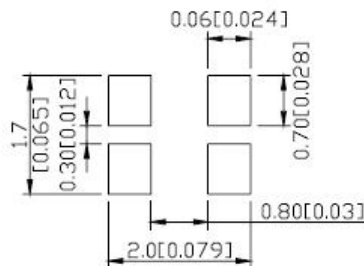

Static Electricity

It is recommended that a wrist band or an anti-electrostatic glove be used when handling the LEDs.

All devices, equipment and machinery must be properly grounded.

Damaged LEDs will show some unusual characteristics such as the forward voltage becomes lower, or the LEDs do not light at the low current. Criteria : (VF > 2.0V at IF=0.5mA)

(3) Moisture Proof Package

It is recommended that moisture proof package be used .

(4)Cautions:

4.1.Please check if there is air leak before opening the package, if so, please return the goods back to take drying process for later using.

4.2 Products can be used within 15days after packaging, after that, they must be:

4.2.1 Soldered within 24 hrs

4.2.2 Used in the condition: 30°C within and 60%RH below

4.2.3 Stored in 30%RH for moisture below.

4.3.Products cannot be used for and over 15days after being packaged unless opening the package and take drying our process in 85°C/6H.

4.4.Products not be used for or over 60days after being packaged please return back to take drying out and packaging process for forward using.

4.5.Products not be used after opening the package need to be dried out for 85°C/6H

PACKAGING

The LEDs are packed in cardboard boxes after taping.

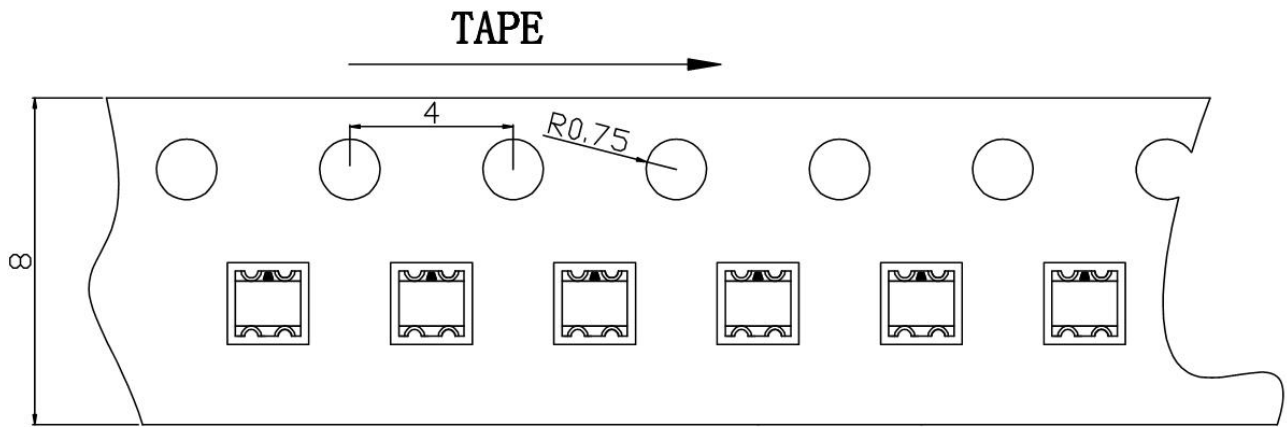

Package: 4000 pcs/reel

Reel Dimensions

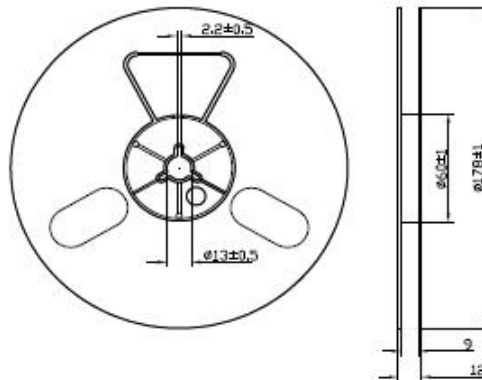

Moisture Resistant Packaging

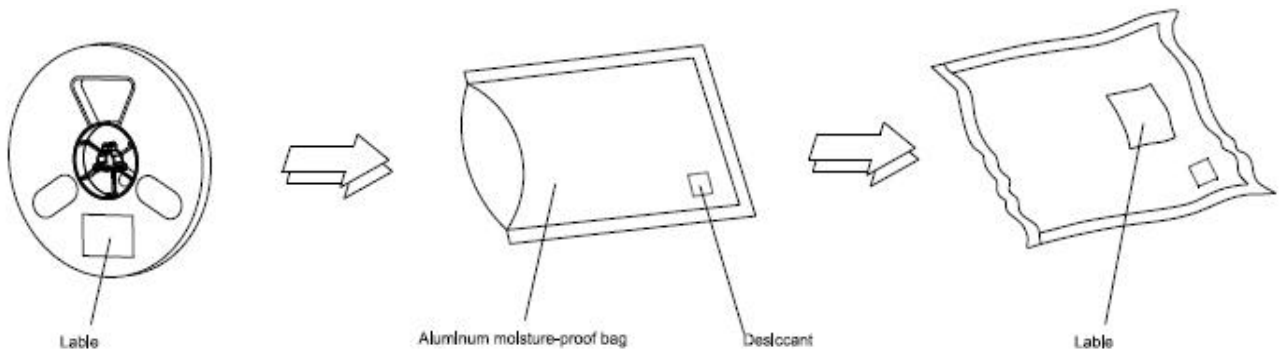

Note: The tolerances unless mentioned is $\pm 0.1\text{mm}$, Unit: mm