



Data Sheet

Customer: _____

Part No: _____

CL-SFC609DBW-5.7K-02

Sample No: _____

Description: _____

5630 SMD White Color

Item No: _____

Customer			
Check	Inspection	Approval	Date

◆ Features

- * Small package with high efficiency
- * Low voltage operation, Instant light
- * Long operation life
- * Lead free product
- * RoHS compliant

◆ Applications :

- | | |
|---|---|
| <ul style="list-style-type: none"> * Mobile phone flash * Automotive interior lighting * Automotive forward lighting * Architectural lighting * LCD TV / Monitor backlight | <ul style="list-style-type: none"> * Traffic signals * Task lighting * Decorative/ Pathway lighting * Remote / Solar powered lighting * Household appliances |
|---|---|

Device Selection Guide

ITEM	MATERIALS
Resin	Silicon
Bonding wire	25 Em Au
Lens color	Water Clear
Dice	InGaN

REFLECTOR COATING TYPE HIGH-PERFORMANCE

LEDs High Performance SMD Single-Color Top LEDs

1. Dimensions

(Units):(mm)

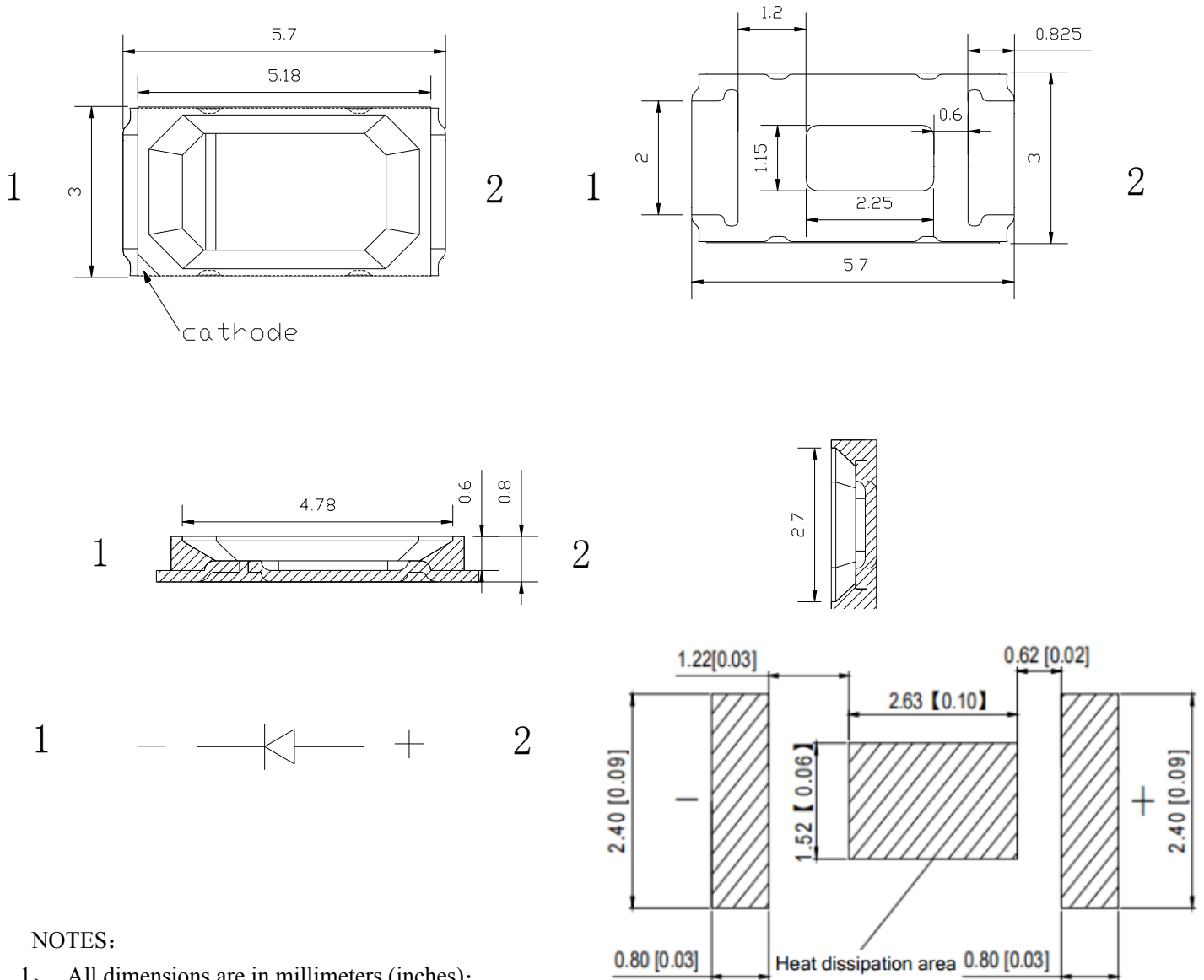

NOTES:

- 1、 All dimensions are in millimeters (inches);
- 2、 Tolerances are 0.2mm (0.008inch) unless otherwise noted

◆ Absolute Maximum Ratings ($T_A=25^{\circ}\text{C}$)

Parameter	Symbol	Rating	Unit
Power Dissipation	P_D	0.5	W
Forward Current	I_F	150	mA
Peak Forward Current*	I_{FP}	200	mA
Operation Temperature Range	T_{opr}	-35 to +60	$^{\circ}\text{C}$
Storage Temperature Range	T_{stg}	-40 to +70	$^{\circ}\text{C}$
ESD Sensitivity (HBM)	--	2000	V
Soldering Temperature	$300 \pm 20^{\circ}\text{C}/3 \sim 5\text{sec}$		

NOTE: * Pulse width $\leq 0.1\text{msec}$ Duty Ratio $\leq 1/10$

◆ Electrical-Optical Characteristics ($T_A=25^{\circ}\text{C}$)

Parameter	Test Condition	Symbol	Min	Typ	Max	Unit
Forward Voltage	$I_F=150\text{mA}$	V_F	3.0	---	3.4	V
Reverse Current	$V_R=-5\text{V}$	I_R	---	---	5	μA
View Angle	$I_F=150\text{mA}$	$2\theta_{1/2}$	---	120	---	deg.
Luminous flux	$I_F=150\text{mA}$	Φ_v	55	---	70	lm
Color Coordinates	$I_F=150\text{mA}$	X	---	0.34	---	
		Y	---	0.34	---	
Color Temperature	$I_F=150\text{mA}$	CCT	5500	---	6500	K
Color Rendering index	$I_F=150\text{mA}$	Ra	---	80	---	---

◆ **Typical Electrical/Optical Characteristic Curves**($I_f=150\text{mA}; T_A=25^\circ\text{C}$)

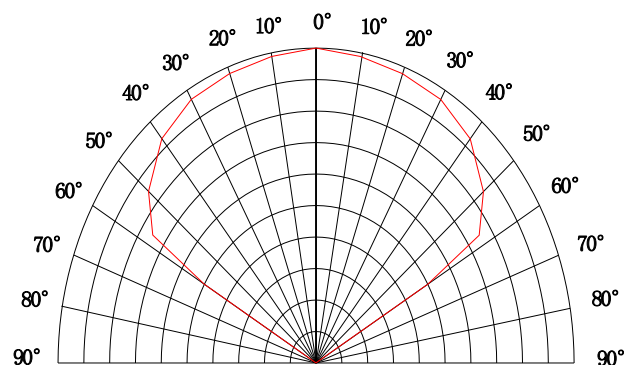
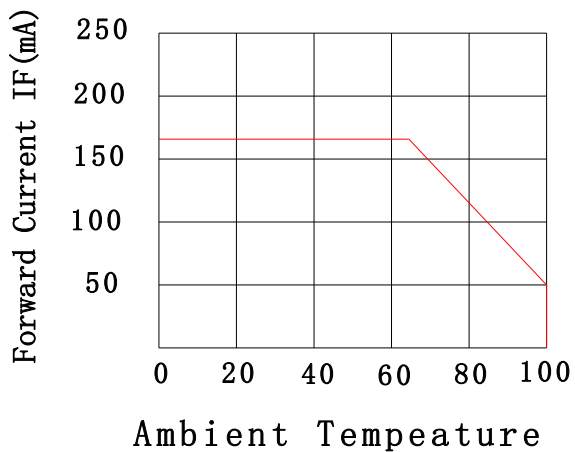
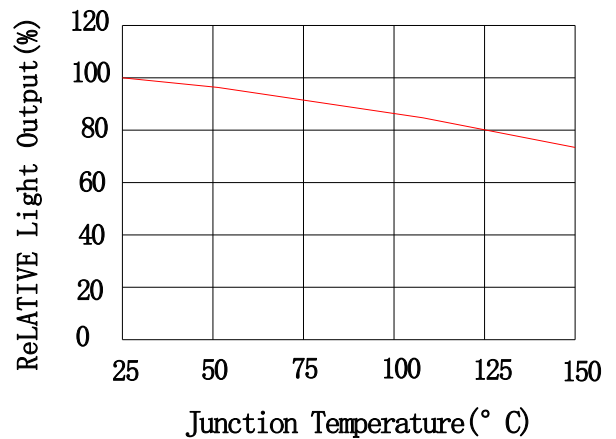
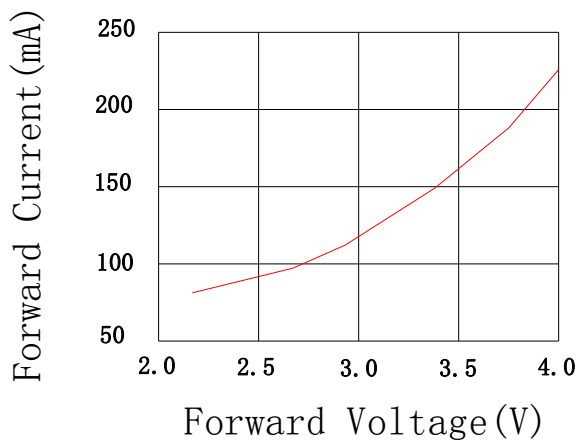
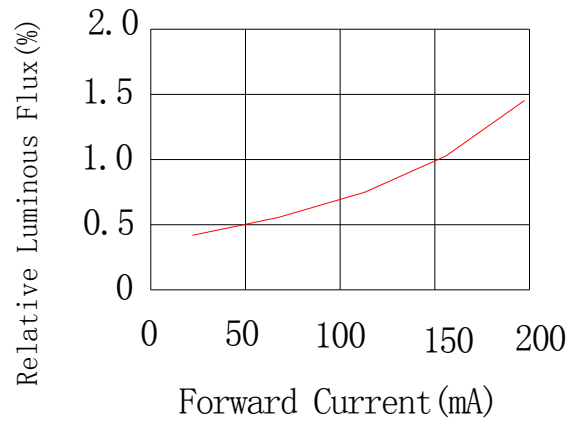
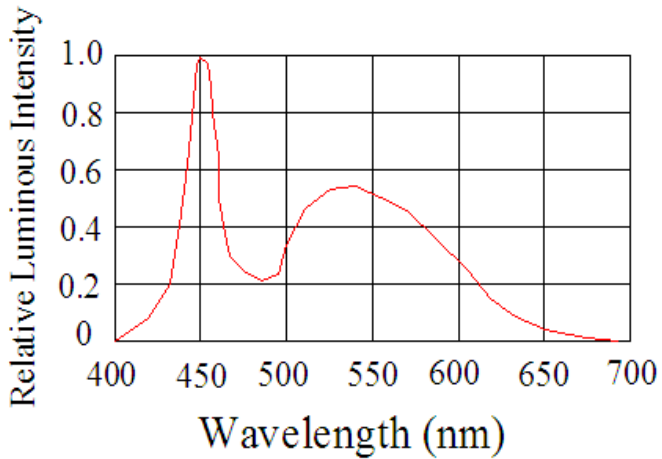

◆ CIE Chromaticity Diagram: (If=150mA; TA=25°C)

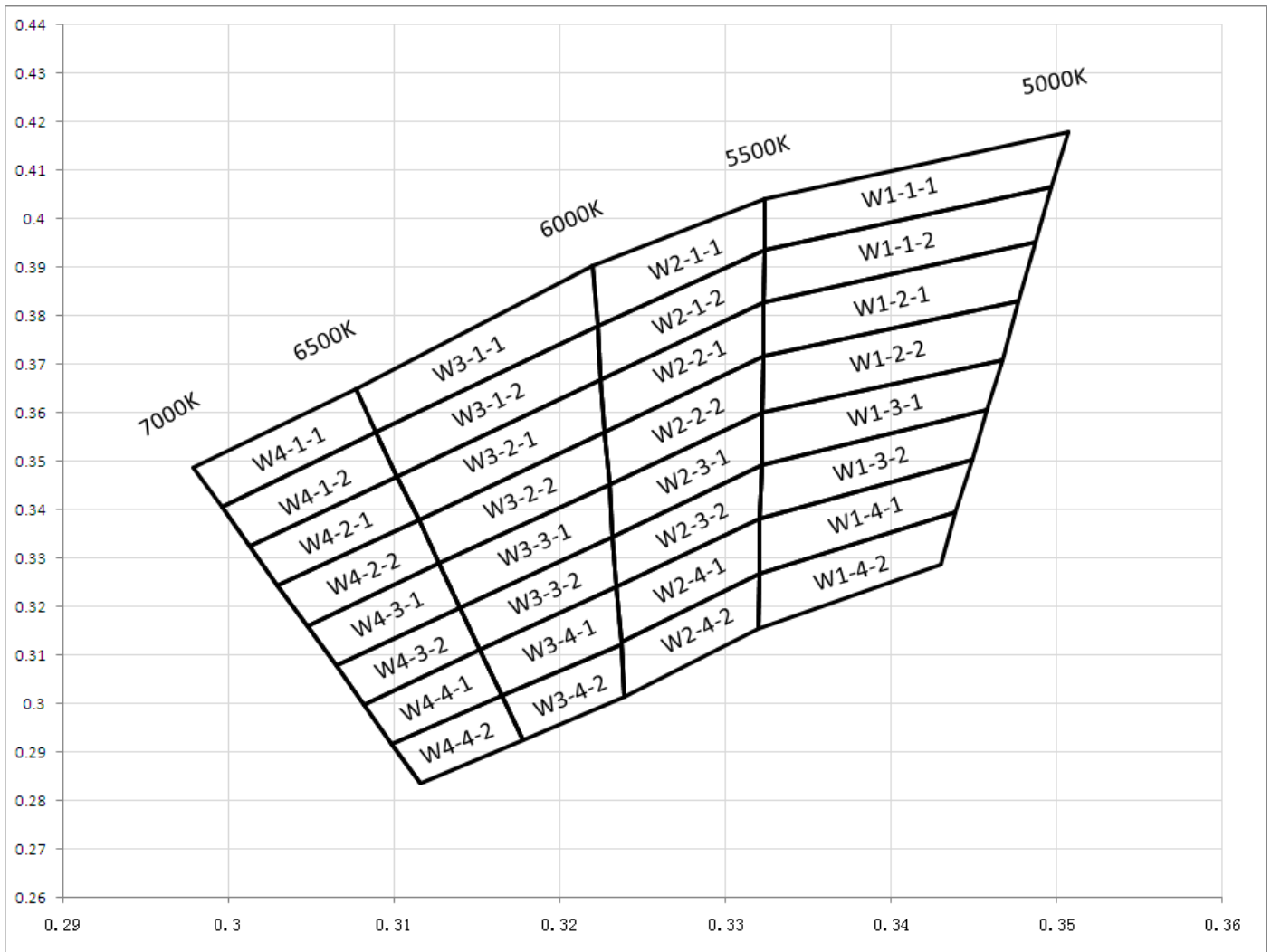

Reliability

1. Test Items And Results

Item	Test conditions	Note	Number of Damaged
Reflow	Temp:260℃ max T=10 sec	2 time	0/30
Thermal Shock	-40~100℃ 10min, 5s, 10min	100cycles	0/30
Temperature Cycle	-40℃~100℃ 60min 20min 60min	20cycles	0/30
High Temperature High Humidity Storage	Ta=60℃,RH=90%	300hrs	0/30
Steady State Operating life	Ta=25℃,IF=150mA	1000hrs	0/30
Steady State Operating life of High Humidity Heat	Ta=60℃ RH=90%,IF=150mA	1000hrs	0/30
High Temperature Storage	Ta=100℃	1000HRS	0/30
Low Temperature Storage	Ta=-40℃	1000HRS	0/30

2. Criteria for Judging The Damage

Item	Symbol	Test Conditions	Criteria for Judgment	
			Min.	Max.
Forward Voltage	V_F	$I_F = 150 \text{ mA}$	---	Initial Data $\times 1.1$
Luminous Intensity	I_v	$I_F = 150 \text{ mA}$	Initial Data $\times 0.9$	---
Reverse Current	I_R	$V_R = 5V$	---	Initial Data $\times 2.0$

(Useful hint) :

1、 Hand Soldering

A soldering iron of less than 20W is recommended to be used in Hand Soldering. Please keep the temperature of the soldering iron under 360°C while soldering. Each terminal of the LED is to go for less than 3 seconds and for one time only.

Be careful because the damage of the product is often started at the time of the hand soldering.

2. Reflow Soldering: Use the conditions shown in the under Figure of Pb-Free Reflow Soldering

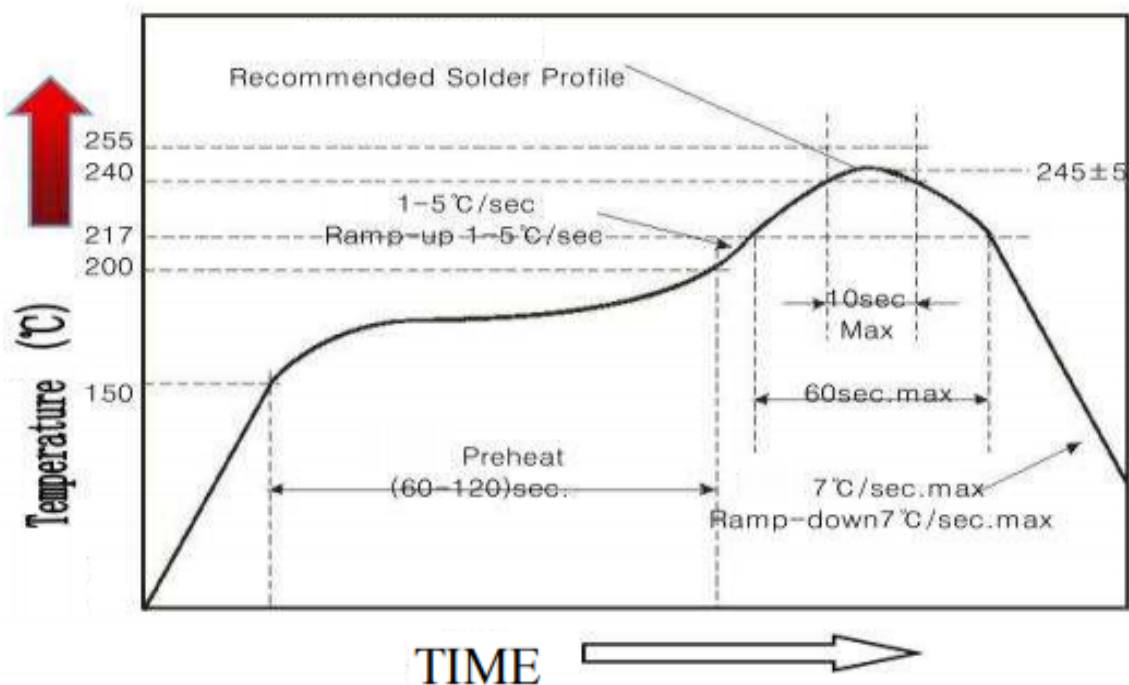

- Reflow soldering only allowed to do once
- Stress on the LEDs should be avoided during heating in soldering process
- After soldering, do not deal with the product before its temperature drop down to room Temperature.

Precautions(1)

1. Storage

- **Moisture proof and anti-electrostatic package with moisture absorbent material is used, to keep moisture to a minimum.**
- **Before opening the package, the product should be kept at 30°C or less and humidity less than 60% RH, and be used within a year.**
- **After opening the package, the product should be stored at 30°C or less and humidity less than 10%RH, and be soldered within 24 hours (1day). It is recommended that the product be operated at the workshop condition of 30°C or less and humidity less than 60%RH.**

- **If the moisture absorbent material has faded away or the LEDs have exceeded the storage time, baking treatment should be performed based on the following condition: (70 ± 5)°C for 24 hours**

2. Static Electricity

Static electricity or surge voltage damages the LEDs. Damaged LEDs will show some unusual characteristics such as the forward voltage becoming lower, or the LEDs do not light at the low current, even not light.

All devices, equipment and machinery must be properly grounded. At the same time, it is recommended that wrist bands or anti-electrostatic gloves, anti-electrostatic containers be used when dealing with the LEDs.

Precautions (2)

3. Vulcanization

LED curing is due to sulfur being in bracket and the +1 price of silver in the chemical reaction generated Ag₂S in the process. It will lead to the capacity of reflecting of silver layer reducing, light color temperature drift and serious decline, seriously affecting the performance of the product. So we should take corresponding measures to avoiding vulcanization, such as to avoid using sulphur volatile substances and keeping away from high sulphur content of the material.

Handling Precautions

- 1、 Handle the component along the side surface by using forceps or appropriate tools; do not directly touch or Handle the silicone lens surface, it may damage the internal circuitry.

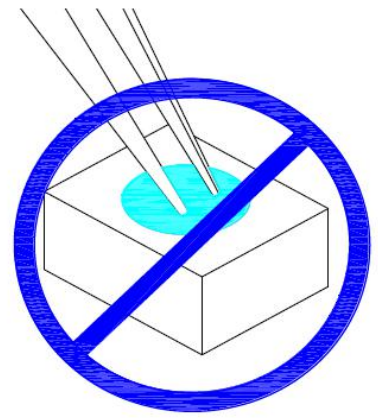
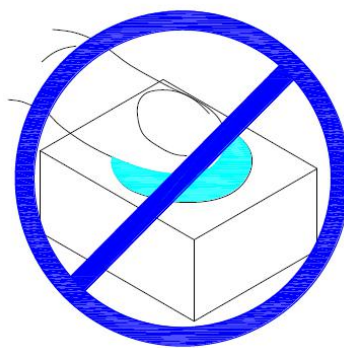
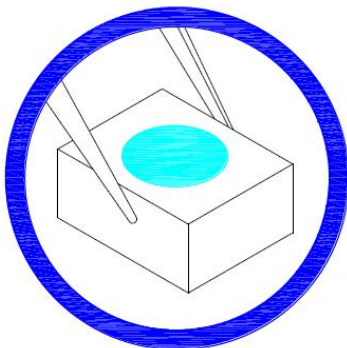

- 2、 Do not stack together assembled PCBs containing LEDs.
PH < 7
Impact may scratch the silicone lens or damage the internal circuitry
- 3、 Not suitable to operate in acidic environment,

