

# Specification

Customer Name : \_\_\_\_\_

Custmer P/N : \_\_\_\_\_

Refond P/N : CL-SFC510WGRBW-2.4K,6.5K-02

Sending Date:

<input checked="" type="checkbox"/> <b>Technical Reference</b>			<input type="checkbox"/> <b>Sample</b>			<input type="checkbox"/> <b>Mass Product</b>		
<b>Customer approval</b>				<b>Refond approval</b>				
<b>Approval</b>	<b>Audit</b>	<b>Confirmation</b>		<b>Approval</b>	<b>Audit</b>	<b>Confirmation</b>		
<input type="checkbox"/> <b>Qualified</b>			<input type="checkbox"/> <b>Disqualified</b>			<b>Date :</b>		

## CL-SFC510WGRBW-2.4K,6.5K-02

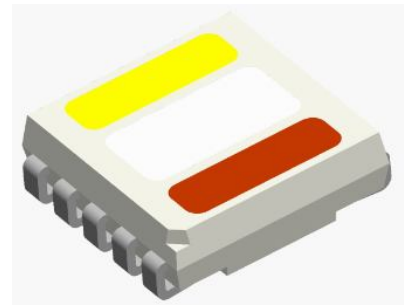

### Features

- PLCC-10 Package.PLCC-10
- Extremely wide viewing angle.
- Suitable for all SMT assembly and solder process.
- Available on tape and reel.
- Moisture sensitivity level: Level 3.
- Package:1000pcs/reel.
- RoHS compliant.

### Description

- The Red source color devices are made with  $\text{AlGaInP}$  on Substrate Light Emitting Diode
- The Green source color devices are made with  $\text{InGaN}$  on Substrate Light Emitting Diode
- The Blue source color devices are made with  $\text{InGaN}$  on Substrate Light Emitting Diode
- The White LED which was fabricated using a blue chip and phosphors.

### Applications

- Optical indicator.
- Indoor display.
- Article color lamp, lamp belt.
- Landscape lighting · Trademark logo.
- General use.

## Package Dimension

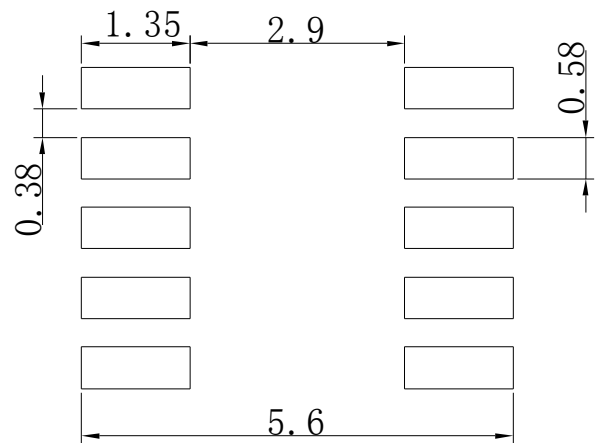
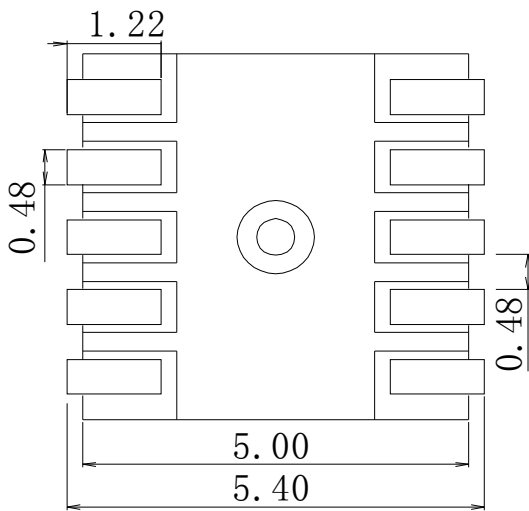
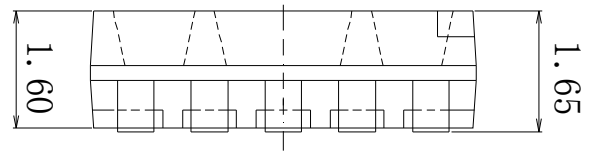
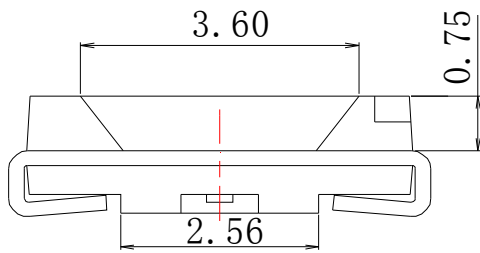
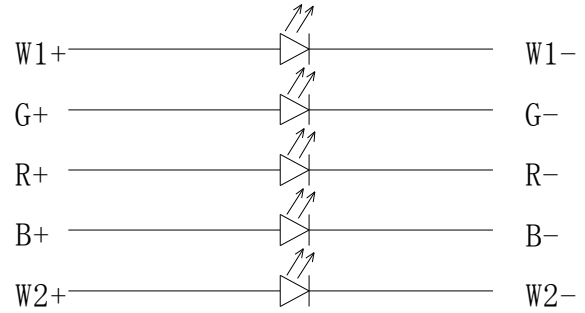
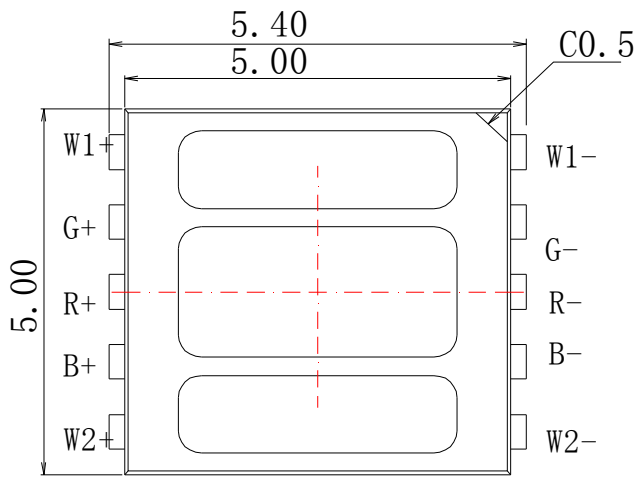

View

Soldering Patterns

### Note:

1. All dimensions units are millimeters.
2. All dimensions tolerances are  $\pm 0.2$ mm unless otherwise noted.

**Electrical / Optical Characteristics at Ts=25°C**

Item	Symbol		test condition	Value			unit
				Min.	Max.	Typ.	
Forward Voltage	Vf	R	IF=20mA	1.95	2.15	---	V
				2.15	2.35	---	V
		G		2.9	3.1	---	V
				3.1	3.3	---	V
		B		3.0	3.2	---	V
				3.2	3.4	---	V
	W1	IF=30mA	2.85	3.05	---	V	
W2	2.85		3.05	---	V		
Luminous intensity	IV	R	IF=20mA	600	900	---	mcd
		G		1200	1800	---	mcd
		B		320	530	---	mcd
	W1(2400K)	IF=30mA	8	10.5	---	lm	
			10.5	13	---	lm	
			10.5	13	---	lm	
Dominant wavelength	WLD	R	IF=20mA	619	625	---	nm
		G		518	521	---	nm
				521	524	---	nm
		B		465	470	---	nm
Reverse Current	VR=5V	IR	---	10	---	uA	
Viewing Angle	2Θ1/2	IF=20mA	---	---	120	Deg	
Color Rendering Index	CRI	IF=30mA	80	---	---	---	

**Absolute Maximum Ratings at Ts=25°C**

Parameter	Symbol	Rating	Units
Power Dissipation	Pd	500	mW
RGB Forward Current	IF	30	mA
W Forward Current	IF	40	mA
Peak Forward Current	IFP	80	mA
Reverse Voltage	VR	5	V
Electrostatic Discharge	ESD	2000	V
Operating Temperature	Topr	-40 ~ +85	°C
Storage Temperature	Tstg	-40 ~ +100	°C
junction temperature	Tj	95	°C

## Note:

1. 1/10 Duty cycle, 0.1ms pulse width.
2. The above forward voltage measurement allowance tolerance is 0.1V.
3. The above wavelength measurement allowance tolerance is  $\pm 1$ nm.
4. the above luminous intensity measurement allowance tolerance  $\pm 10\%$ .
5. Care is to be taken that power dissipation does not exceed the absolute maximum rating of the product.
6. All measurements were made under the standardized environment of Refond.
7. When the LEDs are in operation the maximum current should be decided after measuring the package temperature, junction temperature should not exceed the maximum rate.

### The Chromaticity Diagram

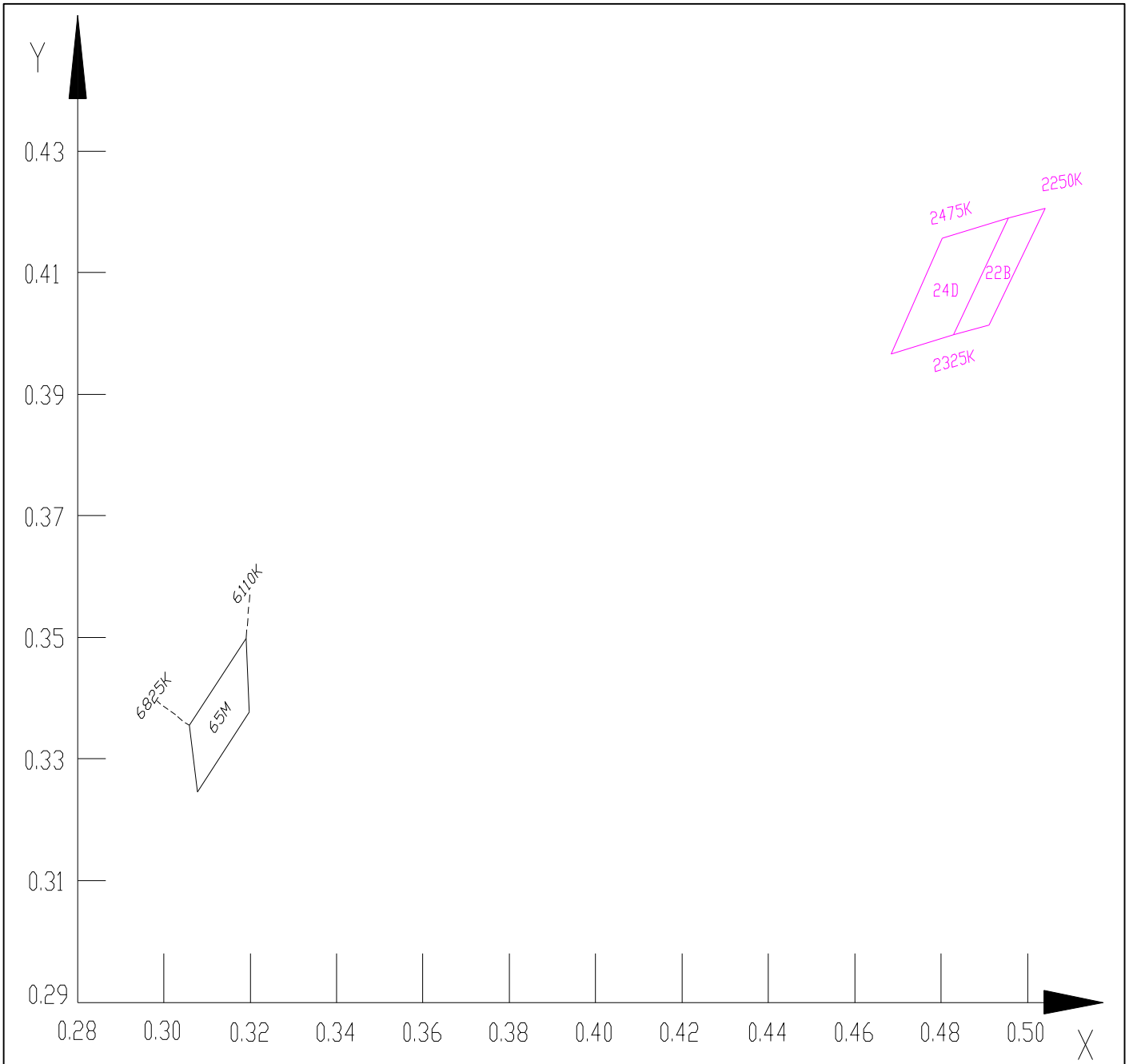

#### Bin data:

BIN CODE	X1	Y1	X2	Y2	X3	Y3	X4	Y4	X5	Y5	X6	Y6
22B	0.4956	0.4191	0.5041	0.4206	0.4911	0.4013	0.4828	0.3998	22B	0.4956	0.4191	0.5041
24D	0.4802	0.4157	0.4956	0.4191	0.4828	0.3998	0.4685	0.3966	24D	0.4802	0.4157	0.4956
65M	0.3058	0.3355	0.3191	0.3499	0.3198	0.3377	0.3078	0.3245	65M	0.3058	0.3355	0.3191

## BIN

Bin code	XY	G-WLD (nm)	R-WLD (nm)	B-WLD (nm)	G-IV (mcd)	R-IV (mcd)	B-IV (mcd)	W1-LM (lm)	W2-LM (lm)	G-VF (v)	R-VF (v)	B-VF (v)	W1-VF (v)	W2-VF (v)
C1	22B 65M	518- 521	619- 625	465- 470	1200- 1800	600- 900	320- 530	8-10.5	10.5- 13	2.9- 3.1	1.95- 2.15	3-3.2	2.85- 3.05	2.85- 3.05
C2	22B 65M	518- 521	619- 625	465- 470	1200- 1800	600- 900	320- 530	8-10.5	10.5- 13	2.9- 3.1	1.95- 2.15	3.2- 3.4	2.85- 3.05	2.85- 3.05
C3	22B 65M	518- 521	619- 625	465- 470	1200- 1800	600- 900	320- 530	8-10.5	10.5- 13	2.9- 3.1	2.15- 2.35	3-3.2	2.85- 3.05	2.85- 3.05
C4	22B 65M	518- 521	619- 625	465- 470	1200- 1800	600- 900	320- 530	8-10.5	10.5- 13	2.9- 3.1	2.15- 2.35	3.2- 3.4	2.85- 3.05	2.85- 3.05
C5	22B 65M	518- 521	619- 625	465- 470	1200- 1800	600- 900	320- 530	8-10.5	10.5- 13	3.1- 3.3	1.95- 2.15	3-3.2	2.85- 3.05	2.85- 3.05
C6	22B 65M	518- 521	619- 625	465- 470	1200- 1800	600- 900	320- 530	8-10.5	10.5- 13	3.1- 3.3	1.95- 2.15	3.2- 3.4	2.85- 3.05	2.85- 3.05
C7	22B 65M	518- 521	619- 625	465- 470	1200- 1800	600- 900	320- 530	8-10.5	10.5- 13	3.1- 3.3	2.15- 2.35	3-3.2	2.85- 3.05	2.85- 3.05
C8	22B 65M	518- 521	619- 625	465- 470	1200- 1800	600- 900	320- 530	8-10.5	10.5- 13	3.1- 3.3	2.15- 2.35	3.2- 3.4	2.85- 3.05	2.85- 3.05
C9	22B 65M	518- 521	619- 625	465- 470	1200- 1800	600- 900	320- 530	10.5- 13	10.5- 13	2.9- 3.1	1.95- 2.15	3-3.2	2.85- 3.05	2.85- 3.05
C10	22B 65M	518- 521	619- 625	465- 470	1200- 1800	600- 900	320- 530	10.5- 13	10.5- 13	2.9- 3.1	1.95- 2.15	3.2- 3.4	2.85- 3.05	2.85- 3.05
C11	22B 65M	518- 521	619- 625	465- 470	1200- 1800	600- 900	320- 530	10.5- 13	10.5- 13	2.9- 3.1	2.15- 2.35	3-3.2	2.85- 3.05	2.85- 3.05
C12	22B 65M	518- 521	619- 625	465- 470	1200- 1800	600- 900	320- 530	10.5- 13	10.5- 13	2.9- 3.1	2.15- 2.35	3.2- 3.4	2.85- 3.05	2.85- 3.05
C13	22B 65M	518- 521	619- 625	465- 470	1200- 1800	600- 900	320- 530	10.5- 13	10.5- 13	3.1- 3.3	1.95- 2.15	3-3.2	2.85- 3.05	2.85- 3.05
C14	22B 65M	518- 521	619- 625	465- 470	1200- 1800	600- 900	320- 530	10.5- 13	10.5- 13	3.1- 3.3	1.95- 2.15	3.2- 3.4	2.85- 3.05	2.85- 3.05
C15	22B 65M	518- 521	619- 625	465- 470	1200- 1800	600- 900	320- 530	10.5- 13	10.5- 13	3.1- 3.3	2.15- 2.35	3-3.2	2.85- 3.05	2.85- 3.05
C16	22B 65M	518- 521	619- 625	465- 470	1200- 1800	600- 900	320- 530	10.5- 13	10.5- 13	3.1- 3.3	2.15- 2.35	3.2- 3.4	2.85- 3.05	2.85- 3.05
C17	24D 65M	518- 521	619- 625	465- 470	1200- 1800	600- 900	320- 530	8-10.5	10.5- 13	2.9- 3.1	1.95- 2.15	3-3.2	2.85- 3.05	2.85- 3.05
C18	24D 65M	518- 521	619- 625	465- 470	1200- 1800	600- 900	320- 530	8-10.5	10.5- 13	2.9- 3.1	1.95- 2.15	3.2- 3.4	2.85- 3.05	2.85- 3.05
C19	24D 65M	518- 521	619- 625	465- 470	1200- 1800	600- 900	320- 530	8-10.5	10.5- 13	2.9- 3.1	2.15- 2.35	3-3.2	2.85- 3.05	2.85- 3.05
C20	24D 65M	518- 521	619- 625	465- 470	1200- 1800	600- 900	320- 530	8-10.5	10.5- 13	2.9- 3.1	2.15- 2.35	3.2- 3.4	2.85- 3.05	2.85- 3.05
C21	24D 65M	518- 521	619- 625	465- 470	1200- 1800	600- 900	320- 530	8-10.5	10.5- 13	3.1- 3.3	1.95- 2.15	3-3.2	2.85- 3.05	2.85- 3.05
C22	24D 65M	518- 521	619- 625	465- 470	1200- 1800	600- 900	320- 530	8-10.5	10.5- 13	3.1- 3.3	1.95- 2.15	3.2- 3.4	2.85- 3.05	2.85- 3.05
C23	24D 65M	518- 521	619- 625	465- 470	1200- 1800	600- 900	320- 530	8-10.5	10.5- 13	3.1- 3.3	2.15- 2.35	3-3.2	2.85- 3.05	2.85- 3.05
C24	24D 65M	518- 521	619- 625	465- 470	1200- 1800	600- 900	320- 530	8-10.5	10.5- 13	3.1- 3.3	2.15- 2.35	3.2- 3.4	2.85- 3.05	2.85- 3.05
C25	24D 65M	518- 521	619- 625	465- 470	1200- 1800	600- 900	320- 530	10.5- 13	10.5- 13	2.9- 3.1	1.95- 2.15	3-3.2	2.85- 3.05	2.85- 3.05
C26	24D 65M	518- 521	619- 625	465- 470	1200- 1800	600- 900	320- 530	10.5- 13	10.5- 13	2.9- 3.1	1.95- 2.15	3.2- 3.4	2.85- 3.05	2.85- 3.05
C27	24D 65M	518- 521	619- 625	465- 470	1200- 1800	600- 900	320- 530	10.5- 13	10.5- 13	2.9- 3.1	2.15- 2.35	3-3.2	2.85- 3.05	2.85- 3.05
C28	24D 65M	518- 521	619- 625	465- 470	1200- 1800	600- 900	320- 530	10.5- 13	10.5- 13	2.9- 3.1	2.15- 2.35	3.2- 3.4	2.85- 3.05	2.85- 3.05
C29	24D 65M	518- 521	619- 625	465- 470	1200- 1800	600- 900	320- 530	10.5- 13	10.5- 13	3.1- 3.3	1.95- 2.15	3-3.2	2.85- 3.05	2.85- 3.05
C30	24D 65M	518- 521	619- 625	465- 470	1200- 1800	600- 900	320- 530	10.5- 13	10.5- 13	3.1- 3.3	1.95- 2.15	3.2- 3.4	2.85- 3.05	2.85- 3.05
C31	24D 65M	518- 521	619- 625	465- 470	1200- 1800	600- 900	320- 530	10.5- 13	10.5- 13	3.1- 3.3	2.15- 2.35	3-3.2	2.85- 3.05	2.85- 3.05
C32	24D6 5M	518- 521	619- 625	465- 470	1200- 1800	600- 900	320- 530	10.5- 13	10.5- 13	3.1- 3.3	2.15- 2.35	3.2- 3.4	2.85- 3.05	2.85- 3.05

**BIN**

Bin code	XY	G-WLD (nm)	R-WLD (nm)	B-WLD (nm)	G-IV (mcd)	R-IV (mcd)	B-IV (mcd)	W1-LM (lm)	W2-LM (lm)	G-VF (v)	R-VF (v)	B-VF (v)	W1-VF (v)	W2-VF (v)
C33	22B 65M	521- 524	619- 625	465- 470	1200- 1800	600- 900	320- 530	8- 10.5	10.5- 13	2.9- 3.1	1.95- 2.15	3-3.2	2.85- 3.05	2.85- 3.05
C34	22B 65M	521- 524	619- 625	465- 470	1200- 1800	600- 900	320- 530	8- 10.5	10.5- 13	2.9- 3.1	1.95- 2.15	3.2- 3.4	2.85- 3.05	2.85- 3.05
C35	22B 65M	521- 524	619- 625	465- 470	1200- 1800	600- 900	320- 530	8- 10.5	10.5- 13	2.9- 3.1	2.15- 2.35	3-3.2	2.85- 3.05	2.85- 3.05
C36	22B 65M	521- 524	619- 625	465- 470	1200- 1800	600- 900	320- 530	8- 10.5	10.5- 13	2.9- 3.1	2.15- 2.35	3.2- 3.4	2.85- 3.05	2.85- 3.05
C37	22B 65M	521- 524	619- 625	465- 470	1200- 1800	600- 900	320- 530	8- 10.5	10.5- 13	3.1- 3.3	1.95- 2.15	3-3.2	2.85- 3.05	2.85- 3.05
C38	22B 65M	521- 524	619- 625	465- 470	1200- 1800	600- 900	320- 530	8- 10.5	10.5- 13	3.1- 3.3	1.95- 2.15	3.2- 3.4	2.85- 3.05	2.85- 3.05
C39	22B 65M	521- 524	619- 625	465- 470	1200- 1800	600- 900	320- 530	8- 10.5	10.5- 13	3.1- 3.3	2.15- 2.35	3-3.2	2.85- 3.05	2.85- 3.05
C40	22B 65M	521- 524	619- 625	465- 470	1200- 1800	600- 900	320- 530	8- 10.5	10.5- 13	3.1- 3.3	2.15- 2.35	3.2- 3.4	2.85- 3.05	2.85- 3.05
C41	22B 65M	521- 524	619- 625	465- 470	1200- 1800	600- 900	320- 530	10.5- 13	10.5- 13	2.9- 3.1	1.95- 2.15	3-3.2	2.85- 3.05	2.85- 3.05
C42	22B 65M	521- 524	619- 625	465- 470	1200- 1800	600- 900	320- 530	10.5- 13	10.5- 13	2.9- 3.1	1.95- 2.15	3.2- 3.4	2.85- 3.05	2.85- 3.05
C43	22B 65M	521- 524	619- 625	465- 470	1200- 1800	600- 900	320- 530	10.5- 13	10.5- 13	2.9- 3.1	2.15- 2.35	3-3.2	2.85- 3.05	2.85- 3.05
C44	22B 65M	521- 524	619- 625	465- 470	1200- 1800	600- 900	320- 530	10.5- 13	10.5- 13	2.9- 3.1	2.15- 2.35	3.2- 3.4	2.85- 3.05	2.85- 3.05
C45	22B 65M	521- 524	619- 625	465- 470	1200- 1800	600- 900	320- 530	10.5- 13	10.5- 13	3.1- 3.3	1.95- 2.15	3-3.2	2.85- 3.05	2.85- 3.05
C46	22B 65M	521- 524	619- 625	465- 470	1200- 1800	600- 900	320- 530	10.5- 13	10.5- 13	3.1- 3.3	1.95- 2.15	3.2- 3.4	2.85- 3.05	2.85- 3.05
C47	22B 65M	521- 524	619- 625	465- 470	1200- 1800	600- 900	320- 530	10.5- 13	10.5- 13	3.1- 3.3	2.15- 2.35	3-3.2	2.85- 3.05	2.85- 3.05
C48	22B 65M	521- 524	619- 625	465- 470	1200- 1800	600- 900	320- 530	10.5- 13	10.5- 13	3.1- 3.3	2.15- 2.35	3.2- 3.4	2.85- 3.05	2.85- 3.05
C49	24D 65M	521- 524	619- 625	465- 470	1200- 1800	600- 900	320- 530	8- 10.5	10.5- 13	2.9- 3.1	1.95- 2.15	3-3.2	2.85- 3.05	2.85- 3.05
C50	24D 65M	521- 524	619- 625	465- 470	1200- 1800	600- 900	320- 530	8- 10.5	10.5- 13	2.9- 3.1	1.95- 2.15	3.2- 3.4	2.85- 3.05	2.85- 3.05
C51	24D 65M	521- 524	619- 625	465- 470	1200- 1800	600- 900	320- 530	8- 10.5	10.5- 13	2.9- 3.1	2.15- 2.35	3-3.2	2.85- 3.05	2.85- 3.05
C52	24D 65M	521- 524	619- 625	465- 470	1200- 1800	600- 900	320- 530	8- 10.5	10.5- 13	2.9- 3.1	2.15- 2.35	3.2- 3.4	2.85- 3.05	2.85- 3.05
C53	24D 65M	521- 524	619- 625	465- 470	1200- 1800	600- 900	320- 530	8- 10.5	10.5- 13	3.1- 3.3	1.95- 2.15	3-3.2	2.85- 3.05	2.85- 3.05
C54	24D 65M	521- 524	619- 625	465- 470	1200- 1800	600- 900	320- 530	8- 10.5	10.5- 13	3.1- 3.3	1.95- 2.15	3.2- 3.4	2.85- 3.05	2.85- 3.05
C55	24D 65M	521- 524	619- 625	465- 470	1200- 1800	600- 900	320- 530	8- 10.5	10.5- 13	3.1- 3.3	2.15- 2.35	3-3.2	2.85- 3.05	2.85- 3.05
C56	24D 65M	521- 524	619- 625	465- 470	1200- 1800	600- 900	320- 530	8- 10.5	10.5- 13	3.1- 3.3	2.15- 2.35	3.2- 3.4	2.85- 3.05	2.85- 3.05
C57	24D 65M	521- 524	619- 625	465- 470	1200- 1800	600- 900	320- 530	10.5- 13	10.5- 13	2.9- 3.1	1.95- 2.15	3-3.2	2.85- 3.05	2.85- 3.05
C58	24D 65M	521- 524	619- 625	465- 470	1200- 1800	600- 900	320- 530	10.5- 13	10.5- 13	2.9- 3.1	1.95- 2.15	3.2- 3.4	2.85- 3.05	2.85- 3.05
C59	24D 65M	521- 524	619- 625	465- 470	1200- 1800	600- 900	320- 530	10.5- 13	10.5- 13	2.9- 3.1	2.15- 2.35	3-3.2	2.85- 3.05	2.85- 3.05
C60	24D 65M	521- 524	619- 625	465- 470	1200- 1800	600- 900	320- 530	10.5- 13	10.5- 13	2.9- 3.1	2.15- 2.35	3.2- 3.4	2.85- 3.05	2.85- 3.05
C61	24D 65M	521- 524	619- 625	465- 470	1200- 1800	600- 900	320- 530	10.5- 13	10.5- 13	3.1- 3.3	1.95- 2.15	3-3.2	2.85- 3.05	2.85- 3.05
C62	24D 65M	521- 524	619- 625	465- 470	1200- 1800	600- 900	320- 530	10.5- 13	10.5- 13	3.1- 3.3	1.95- 2.15	3.2- 3.4	2.85- 3.05	2.85- 3.05
C63	24D 65M	521- 524	619- 625	465- 470	1200- 1800	600- 900	320- 530	10.5- 13	10.5- 13	3.1- 3.3	2.15- 2.35	3-3.2	2.85- 3.05	2.85- 3.05
C64	24D 65M	521- 524	619- 625	465- 470	1200- 1800	600- 900	320- 530	10.5- 13	10.5- 13	3.1- 3.3	2.15- 2.35	3.2- 3.4	2.85- 3.05	2.85- 3.05



RGB Typical Optical Characteristics Curves RGB

Fig.1-Forward Voltage Vs. Forward Current

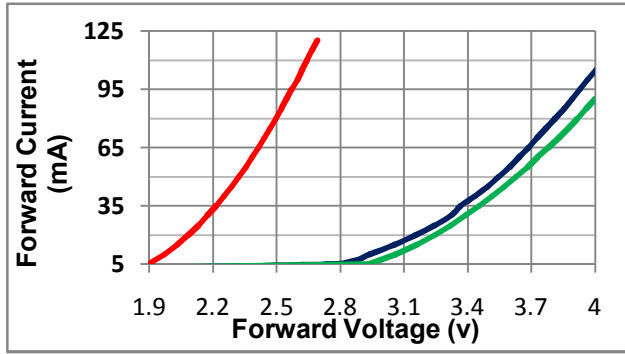

Fig.2-Forward Current Vs. Relative Intensity

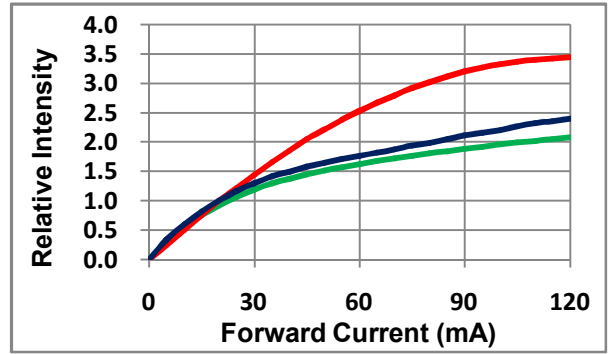

Fig.3-Temperature Vs. Relative Intensity

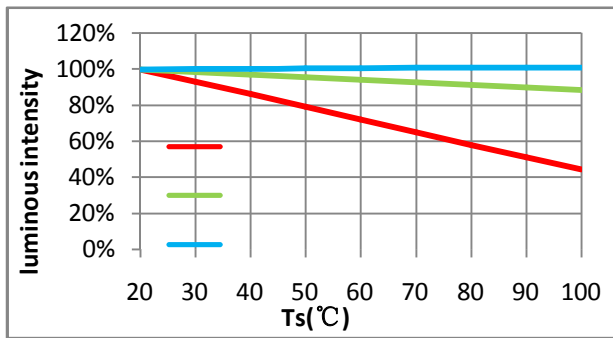

Fig.4- Spectrum Distribution

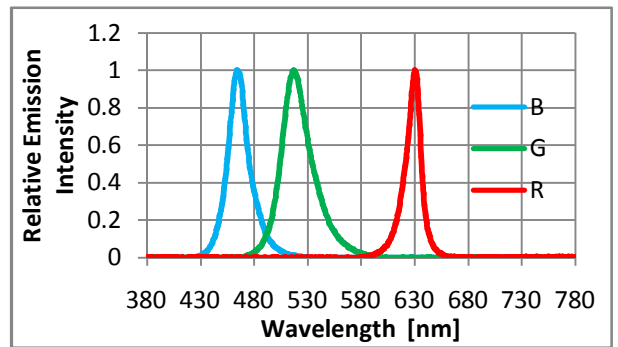

Fig.5-Forward Voltage Vs. Temperature

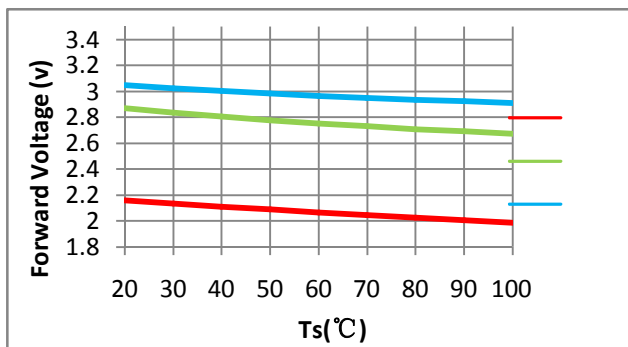
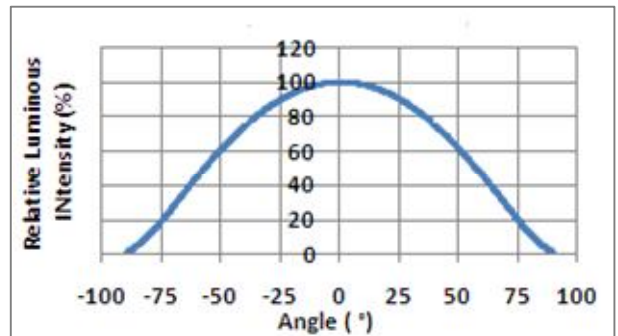
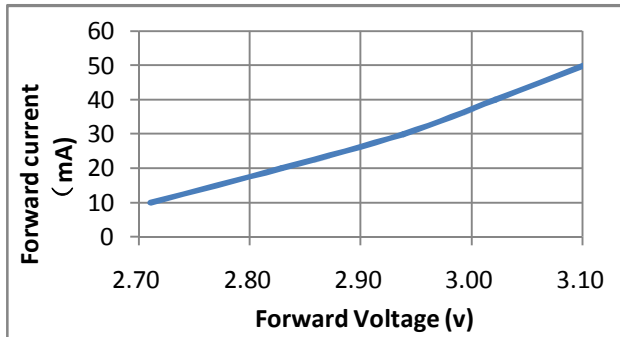

Fig.6-Radiation diagram



## W1/W2 Typical Optical Characteristics Curves W1/W2

**Fig.1-Forward Voltage Vs. Forward Current**



**Fig.2-Forward Current Vs. Relative Intensity**

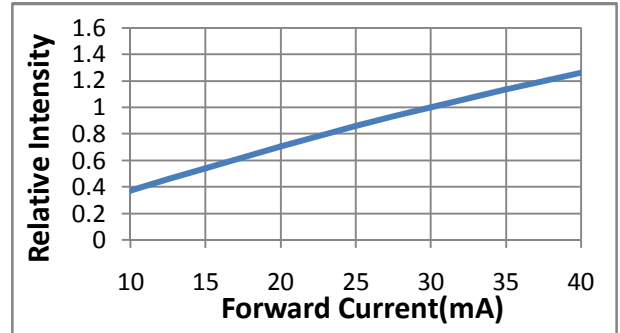

**Fig.3- Pin Temperature Vs. Relative Intensity**

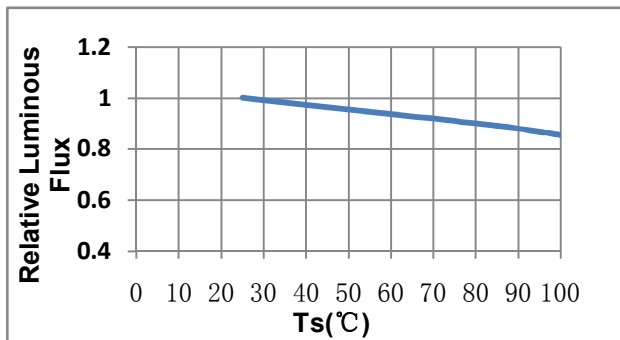

**Fig.4-Pin Temperature Vs. Forward Current**

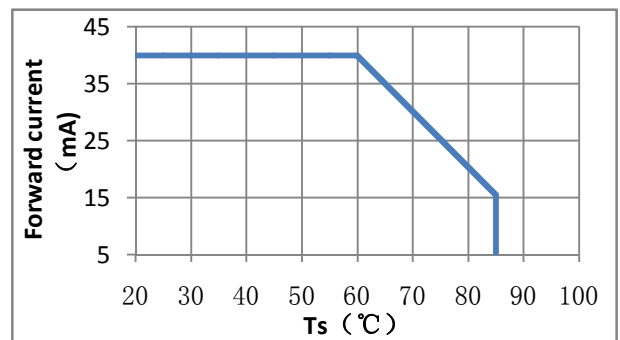

**Fig.5-Forward Voltage Vs.Pin Temperature**

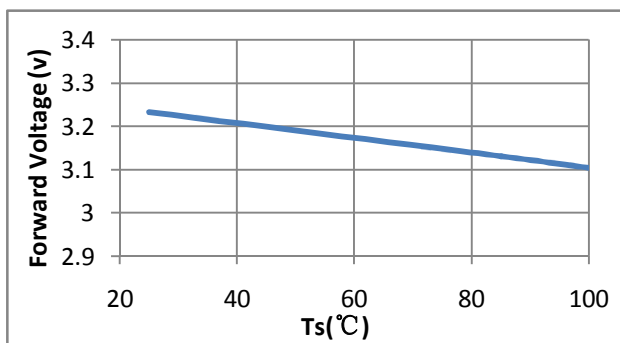

**Fig.6-Radiation diagram**

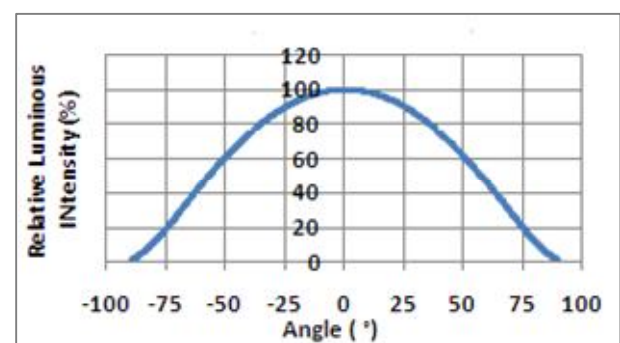

**Fig.7- SpectrumDistribution**

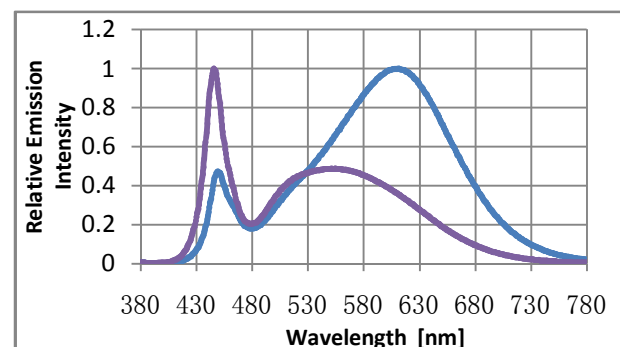

**Note:** All the parameters and standards in the specification are based on Refond standard test platform.

## Packaging Specifications

### ■ Carrier Tape Dimensions

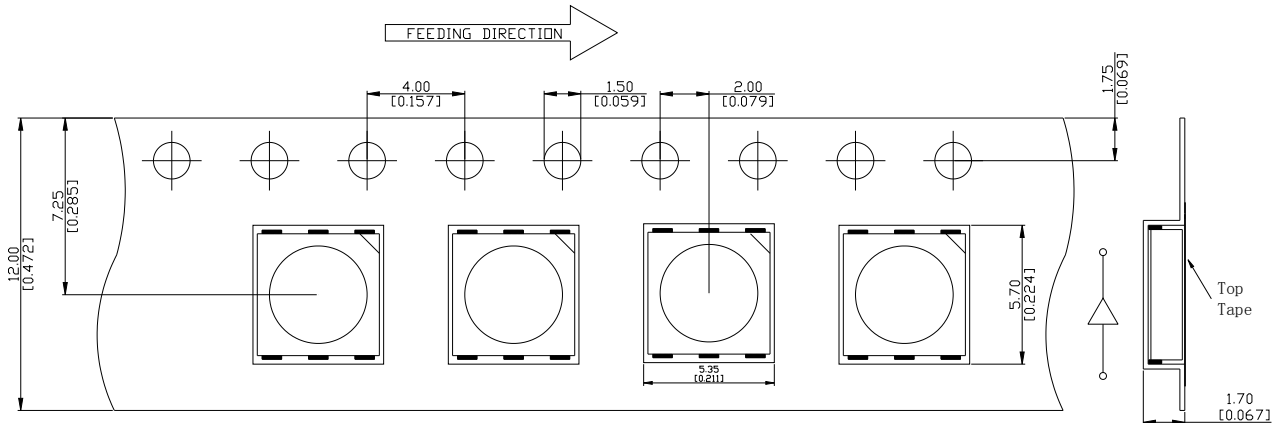

### ■ Reel Dimension

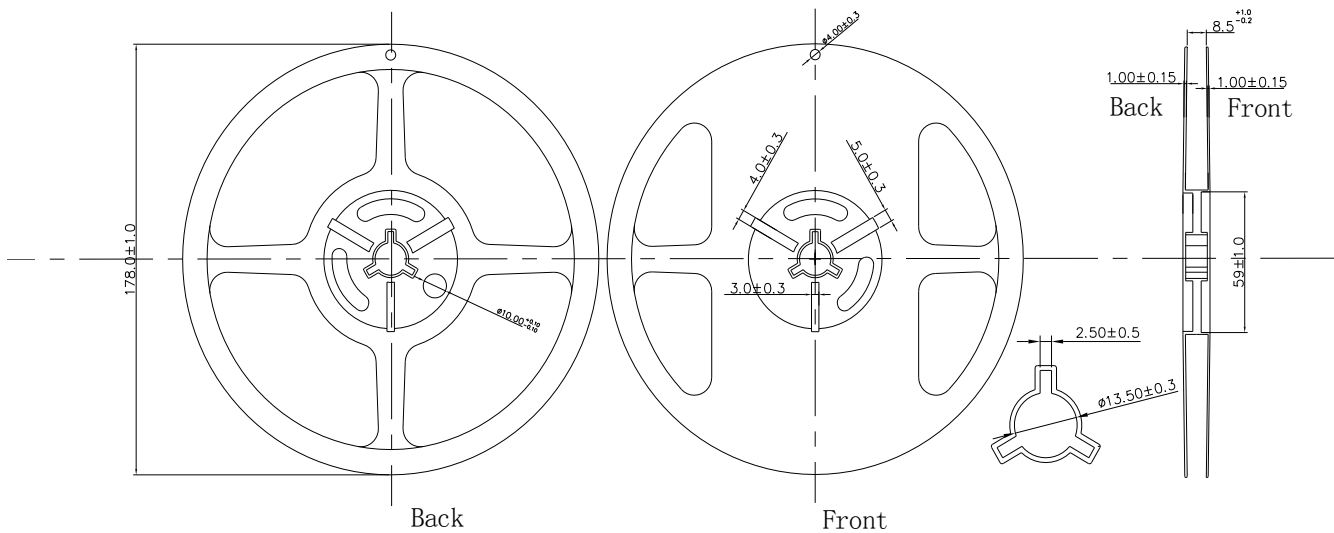

Note:

The tolerances unless mentioned  $\pm 0.1$ mm. Unit : mm

■ Label Form Specification

PART NO. cinvcode	
SPEC NO. cspecno	
LOT NO. lotno	
BIN CODE ;	
XY:	
	QTY:
	DATE:

PART NO.	Part Number
SPEC NO.	Spec Number
LOT NO.	Lot Number
BIN CODE	Bin Code
XY	Bin
QTY	Packing Quantity
DATE	Made Date

■ Moisture Resistant Packing Process

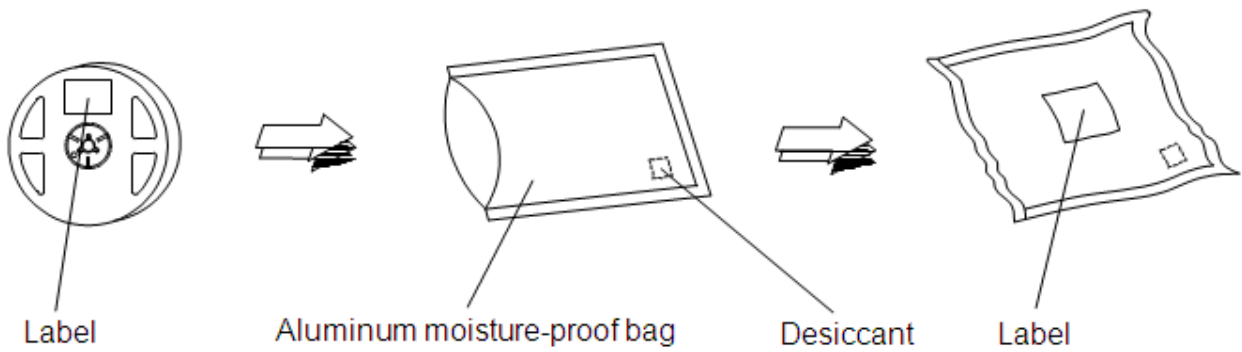

■ Cardboard Box

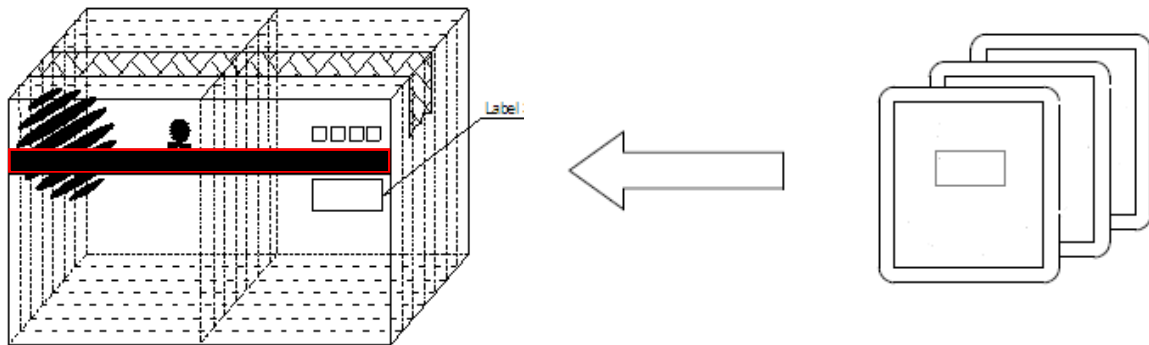

## Reliability Test Items And Conditions

Test Items	Ref.Standard	Test Condition	Time	Quantity	Ac/Re
Reflow	JESD22-B106	Temp:260°Cmax T=10 sec	2times.	10Pcs.	0/1
Thermal Shock	JESD22-A106	-40°C 15min ↑↓ 100°C 15min	100 cycle	10Pcs.	0/1
High Temperature Storage	JESD22-A103	Temp:100°C	1000Hrs.	10Pcs.	0/1
Low Temperature Storage	JESD22-A119	Temp:-40°C	1000Hrs.	10Pcs.	0/1
Life Test	JESD22-A108	Ta=25°C IF=20mA	1000Hrs.	10Pcs.	0/1
High Temperature High Humidity Life Test	JESD22-A101	60°C/ 90%RH IF=20mA	500Hrs.	10Pcs.	0/1

## Criteria For Judging Damage

Test Items	Symbol	Test Condition	Criteria For Judgement	Applicable project
Forward Voltage	Vf	IF=20mA	$\leq \pm 10\%$	Reflow High and Low Temperature Storage Life Test
Luminous Intensity	IV	IF=20mA	Maintenance $\geq 70\%$	
Lamp bead light test	/	IF=20mA	No open circuit, shortcircuit or flicke	High Temperature High Humidity Life Test

U.S.L: Upper standard level

L.S.L: Lower standard level

1>.The Reliability tests are based on Refond existing test platform.

2>.The technical information shown in the data sheets are limited to the typical characteristics and circuit examples of the referenced products. It does not constitute the warranting of industrial property nor the granting of any license.

## SMT Reflow Soldering Instructions SMT

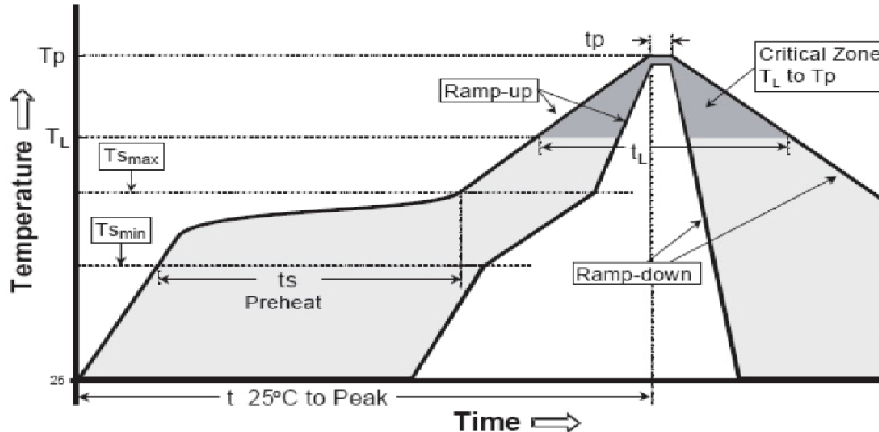

平均升温速度 (T <sub>Smax</sub> 至T <sub>p</sub> )	Up to 3 °C / sec
预热: 最低温度 (T <sub>Smin</sub> )	150 ° C
预热: 最高温度 (T <sub>Smax</sub> )	200 ° C
预热: 时间 (t <sub>Smin</sub> 至t <sub>Smax</sub> )	60 - 120 seconds
限时维持高温: 温度 (T <sub>L</sub> )	217 ° C
限时维持高温: 时间 (t <sub>L</sub> )	Up to 60 seconds
峰值 / 分类温度 (T <sub>p</sub> )	260 ° C
限时峰值分类温度:时间 (t <sub>p</sub> )	Up to 10 seconds
与实际峰值温度 (t <sub>p</sub> ) 低 5 ° C 以内的保持时间	Up to 30 seconds
降温速度	Up to 6 °C / sec
25 ° C 升至峰值温度所需时间	Up to 8 minutes

1.Reflow soldering should not be done more than two times. In the case of more than 24 hours passed soldering after first, LEDs will be damaged.

2.When soldering , do not put stress on the LEDs during heating

### ■ Soldering Iron

1.When hand soldering, keep the temperature of iron below less 300°C less than 3 seconds

2.The hand solder should be done only one time.

### ■ Repairing

Repair should not be done after the LEDs have been soldered. When repairing is unavoidable,a double-head soldering iron should be used (as below figure). It should be confirmed in advance whether the characteristics of LEDs will or will not be damaged by repairing.

### ■ Cautions

1.The encapsulated material of the LEDs is silicone. Therefore the LEDs have a soft surface on the top of package. The pressure to the top surface will be influence to the reliability of the LEDs. Precautions should be taken to avoid the strong pressure on the encapsulated part. So when use the picking up nozzle, the pressure on the silicone resin should be proper.

2. Components should not be mounted on warped (non coplanar) portion of PCB. After soldering, do not warp the circuit board

3. Do not apply mechanical force or excess vibration during the cooling process to normal temperature after soldering. Do not rapidly cool device after soldering.

## Handling Precautions

1>.LED operating environment and sulfur element composition cannot be over 100PPM in the LED mating usage material. This is provided for informational purposes only and is not a warranty or endorsement.

2>.VOCs (Volatile organic compounds) emitted from materials used in the construction of fixtures can penetrate silicone encapsulants of LEDs and discolor when exposed to heat and photonic energy. The result can be a significant loss of light output from the fixture. Knowledge of the properties of the materials selected to be used in the construction of fixtures can help prevent these issues. Refond advises against the use of any chemicals or materials that have been found or are suspected to have an adverse affect on device performance or reliability. To verify compatibility, Refond recommends that all chemicals and materials be tested in the specific application and environment for which they are intended to be used. Attaching LEDs, do not use adhesives that outgas organic vapor.

3>.Handle the component along the side surface by using forceps or appropriate tools; do not directly touch or Handle the silicone lens surface, it may damage the internal circuitry.

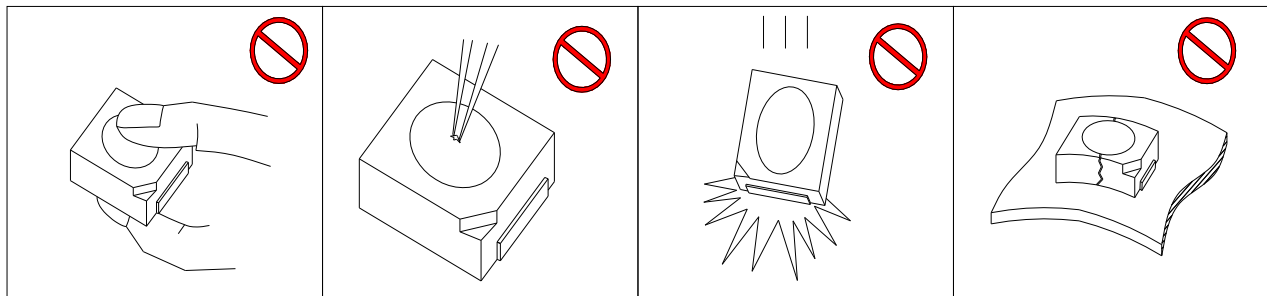

4>. In designing a circuit,the current through each LED must be exceed the absolute maximum rating specified for each LED.In the meanwhile,resistors for protection should be applied,otherwise slight voltage shift will cause big current change,burn out may happen. The driving circuit must be designed to allow forward voltage only when it is ON or OFF.If the reverse voltage is applied to LED, migration can be generated resulting in LED damage.

5>.Thermal Design is paramount importance because heat generation may result in the Characteristics decline,such as brightness decreased,Color change and so on.Please consider the heat generation of the LEDs when making the system design.

6> .Compared to standard encapsulants, silicone is generally softer, and the surface is more likely to attract dust requiring special care during processing. In cases where a minimal level of dirt and dust particles cannot be guaranteed, a suitable cleaning solution must be applied to the surface after the soldering of components. Refond suggests using isopropyl alcohol for cleaning. In case other solvents are used, it must be assured that these solvents do not dissolve the package or resin. Ultrasonic cleaning is not recommended. Ultrasonic cleaning may cause damage to the LED.

7> . Storage

Conditions		Temperature	Humidity	Time
Storage	Before Opening Aluminum Bag	≤30°C	≤75%	Within 1 Year from Delivery Date
	After Opening Aluminum Bag	≤30°C	≤60%	24 hours
Baking		60±5°C	-	≥24hours

If the moisture absorbent material (silica gel) has faded away or the LEDs have exceeded the storage time, baking treatment should be performed after unpacking and based on the following condition: (65±5)°C for above 24 hours.

If the package is flatulence or damaged, please notify the sales staff to assist.

8> .Similar to most Solid state devices; LEDs are sensitive to Electro-Static Discharge (ESD) and Electrical Over Stress (EOS).

9>.There should be Revalidated when there is any change on the use condition(like fixture type, raw material, Radiating change ) after the approval.

10>.When you have special quality requirement for the product, please kindly contact to our sales.

11>.When using LED, clients shall pay attention to the defined specs and using environment requires.Refond will give no quality guarantee on the situation: if using in conditions that out of specs or over reference conditions which without verifying.

12>.The customer shall not disassemble or analyze the LEDs without having consent from Refond. When



defective LEDs are found, the customer shall inform Refond in writing directly before disassembling or analysis.

13>.Other points for attention, please refer to our LED user manual.

## **Declare**

This specification is written both in English and in Chinese and the latter is formal.

Both the customers and will agree on official specifications of supplied products before a customer's volume production. The specification is valid only after be signed. And Refond reserves the right to further modify the specification for technical reference and sample without noticing the customers.