



Data Sheet

Customer: _____
Part No: CL-SP1606DNB-02
Sample No: _____
Description: 1606 SMD Blue Color
Item No: _____

Customer			
Check	Inspection	Approval	Date

Features

- _1.7mmX0.6mm SMT LED, 1.1mm THICKNESS.
- _LOW POWER CONSUMPTION.
- _WIDE VIEWING ANGLE.
- _IDEAL FOR BACKLIGHT AND INDICATOR.
- _VARIOUS COLORS AND LENS TYPES AVAILABLE.
- _PACKAGE: 4000PCS / REEL.
- _RoHS COMPLIANT.

Description

The Blue source color devices are made with GaN on Sapphire Light Emitting Diode.
 Static electricity and surge damage the LEDs.
 It is recommended to use a wrist band or anti-electrostatic glove when handling the LEDs.
 All devices, equipment and machinery must be electrically grounded.
 Emitting Diode.

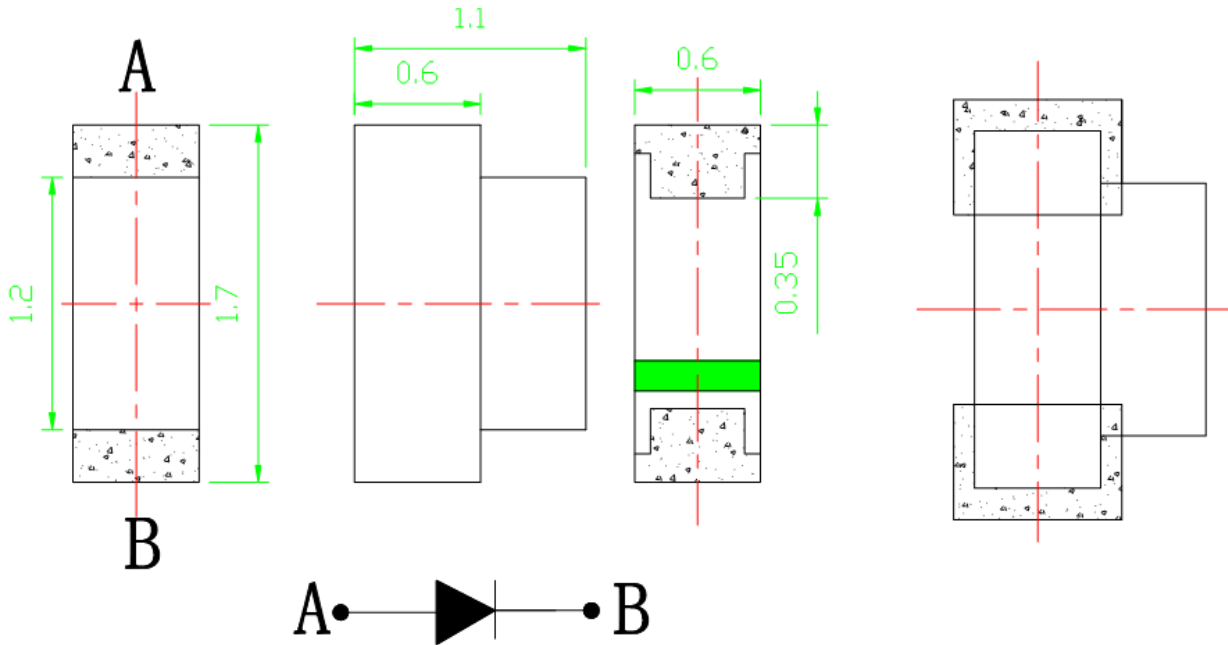
Package Dimensions

Notes:

1. All dimensions are in millimeters (inches).
2. Tolerance is ± 0.1 (0.004") unless otherwise noted.
3. Specifications are subject to change without notice.

Selection Guide

Part No.	Dice	Lens Type	Iv (mcd) @20mA		Viewing Angle
			Min.	Typ.	2 θ 1/2
CL-SP1606DNB-02	BLUE (GaN)	WATER CLEAR	90	180	120

Note:

- θ1/2 is the angle from optical centerline where the luminous intensity is 1/2 the optical centerline value.

Electrical / Optical Characteristics at T_A=25°C

Symbol	Parameter	Device	Typ.	Max.	Units	Test Conditions
λD	Dominant Wavelength	Blue	462	472	nm	IF=20mA
Δλ1/2	Spectral Line Half-width	Blue	25		nm	IF=20mA
C	Capacitance	Blue			pF	VF=0V;f=1MHz
VF	Forward Voltage	Blue	2.6	3.2	V	IF=20mA
IR	Reverse Current	Blue		2	uA	VR = 7V

Remarks:

If special sorting is required (e.g. binning based on forward voltage, luminous intensity, or wavelength), the typical accuracy of the sorting process is as follows:

- Wavelength: +/-1nm
- Luminous Intensity: +/-15%
- Forward Voltage: +/-0.1V

Note: Accuracy may depend on the sorting parameters

Absolute Maximum Ratings at T_A=25°C

Parameter	Blue	Units
Power dissipation	135	mW
DC Forward Current	30	mA
Peak Forward Current [1]	140	mA
Reverse Voltage	5	V
Operating/Storage Temperature	-40°C To +85°C	

Note:

- 1/10 Duty Cycle, 0.1ms Pulse Width.

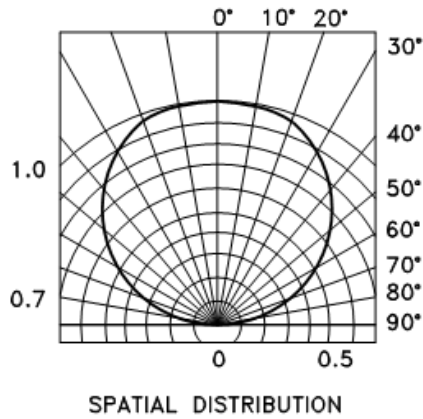
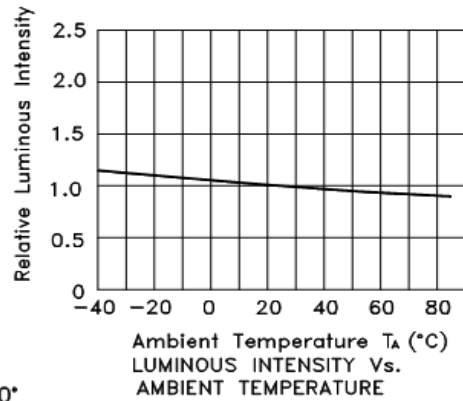
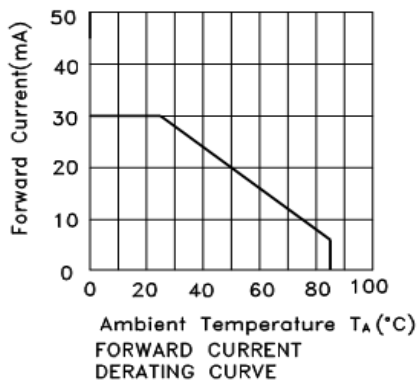
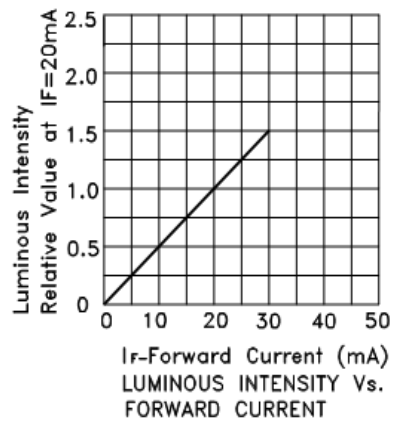
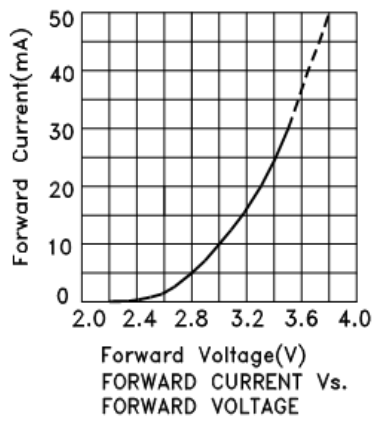
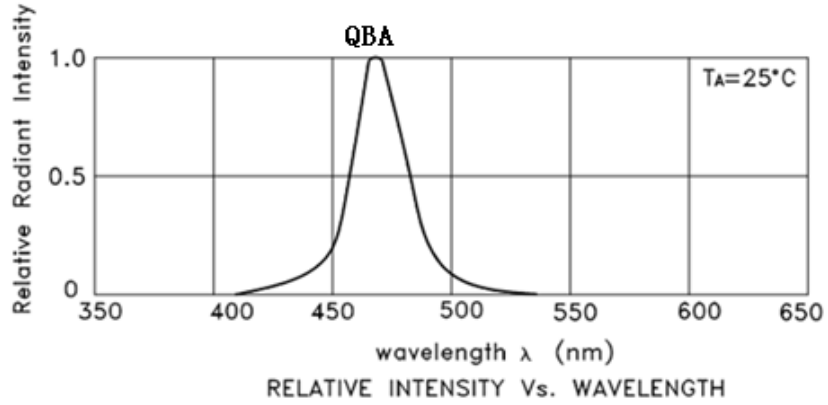

RELIABILITY

Test Items and Results

NO.	Test Item	Reference Standard	Test Condition	(Hours/ Cycles)	Sample	Number of Damaged
1	Temperature Cycle	JEITA ED-4701	-40°C ~ 25°C ~ 100°C ~ 25°C 30 min 5 min 30 min 5 min	100 Cycles	50	0/50
2	Thermal Shock	MIL-STD-202G	-40°C ~ 100°C 15 分钟 15 分钟	500 Cycles	50	0/50
3	High Temperature Storage	JEITA ED-4701 200 201	T _a =100°C	1000 Hours	50	0/50
4	Low Temperature Storage	JEITA ED-4701 200 201	T _a =-40°C	1000 Hours	50	0/50
5	Room Temperature Life Test		T _a =25±5°C I _F =20mA	1000 Hours	50	0/50
6	High Temperature High Humidity Life Test		T _a =60°C RH=85% I _F =20mA	1000 Hours	50	0/50
7	Solderability (Reflow Soldering)	JEITA ED-4701 300 303	T _{sol} =235°C±5°C, 5 sec (Using Flux, Lead Solder)	1 time, 5 sec	10	0/10
8	Resistance to Soldering Heat (Reflow Soldering)	JEITA ED-4701 300 301	T _{sol} =260°C, 10 sec Pre Treatment: 35°C 95%RH 96 Hrs	2 time, 10 sec	10	0/10

The above test items such as differences or special customer specific requirements according to the actual situation in accordance with the requirements of customers to try the requirements with the customer, the customer is not required by our test standard test. Different products using different current test.

5. Cautions

(1) Soldering Conditions

Number of reflow process shall be less than 2 times and cooling process to normal temperature is required between first and Second soldering process.

(Recommended soldering conditions)

回流焊接 Reflow Soldering		手工焊接	
预热温度 Pre-heat	有铅 Lead Solder	无铅 Lead-free Solder	温度 Temperature
预热时间 Pre-heat time	140 ~ 160° C 120 sec. Max.	180 ~ 200° C 120 sec. Max.	焊接时间 Soldering time
峰值温度 Peak temperature	230° C Max. 10 sec. Max.	260° C Max. 10 sec. Max.	350° C Max. 3 sec. Max. (one time only)
焊接时间 Soldering time	参考下图	参考下图	
条件 Condition			

(Lead Solder)

(Lead-Free Solder)

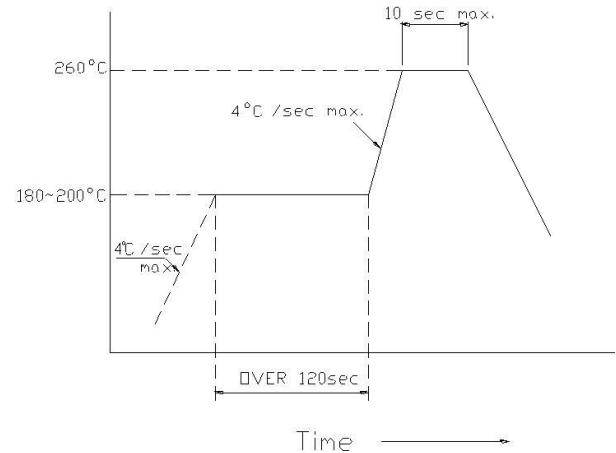
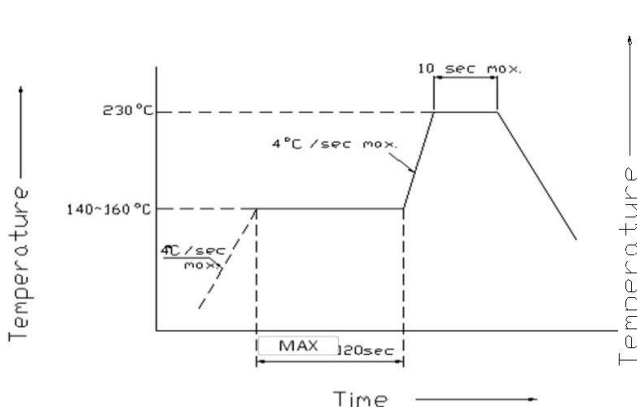

Recommended Sold (Units : mm)

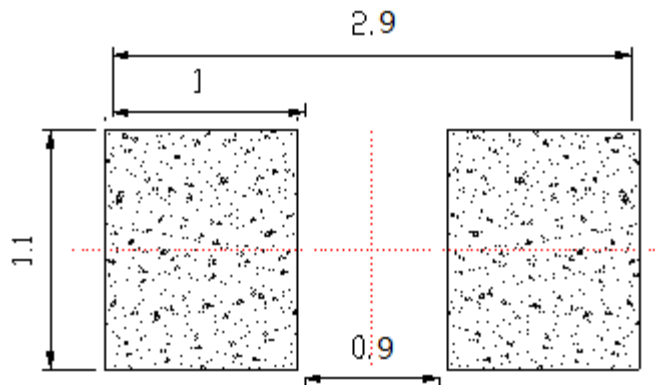

(2) Static Electricity

It is recommended that a wrist band or an anti-electrostatic glove be used when handling the LEDs.

All devices, equipment and machinery must be properly grounded.

Damaged LEDs will show some unusual characteristics such as the forward voltage becomes lower, or the LEDs do not light at the low current. Criteria : (VF > 2.0V at IF=0.5mA)

(3) Moisture Proof Package

It is recommended that moisture proof package be used .

(4) Cautions:

4.1. Please check if there is air leak before opening the package, if so, please return the goods back to take drying process for later using.

4.2 Products can be used within 15days after packaging, after that, they must be:

4.2.1 Soldered within 24 hrs

4.2.2 Used in the condition: 30°C within and 60%RH below

4.2.3 Stored in 30%RH for moisture below.

4.3. Products cannot be used for and over 15days after being packaged unless opening the package and take drying our process in 85°C/6H.

4.4. Products not be used for or over 60days after being packaged please return back to take drying out and packaging process for forward using.

4.5. Products not be used after opening the package need to be dried out for 85°C/6H

PACKAGING

The LEDs are packed in cardboard boxes after taping.

包装方式:

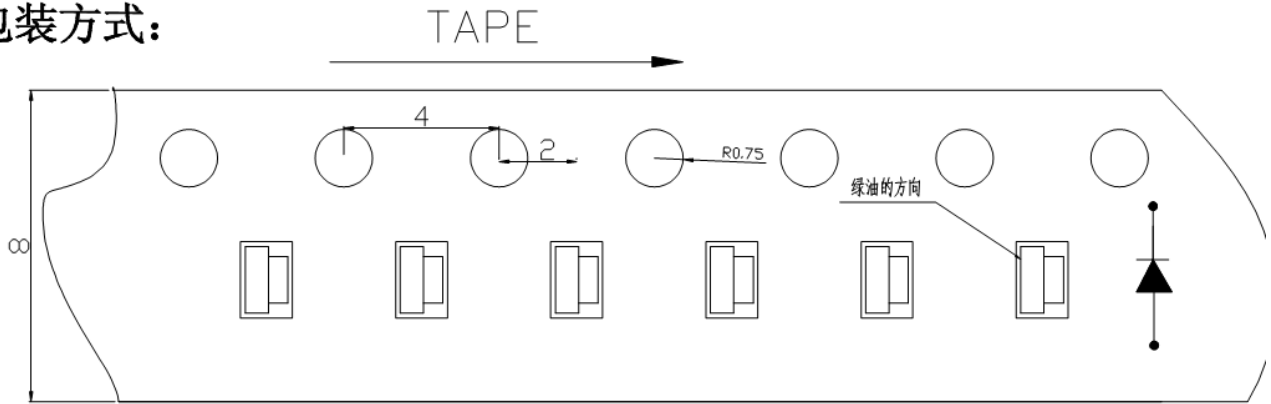

Package: 4000PCS/reel

Reel Dimensions

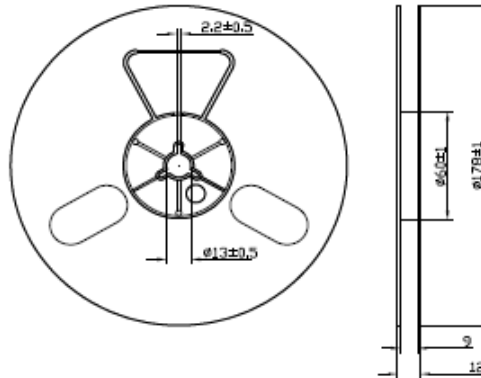

Moisture Resistant Packaging

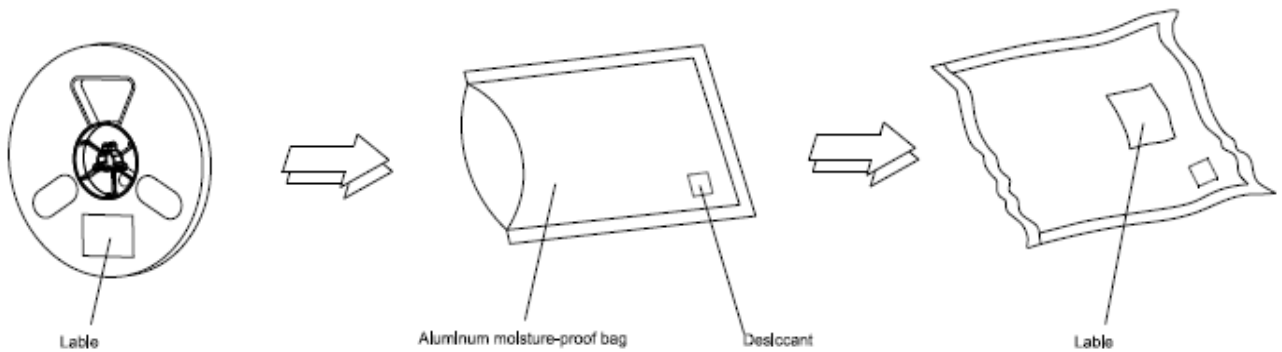

Note: The tolerances unless mentioned is ±0.1mm, Unit: mm