

CL-3W-UWB

Features:

- Long operating life
- Highest flux
- Available in White
- Lambertian radiation pattern
- More energy efficient than incandescent and most halogen lamps
- Low voltage DC operated
- Cool beam, safe to the touch
- Instant light (less than 100ns)
- Fully dimmable
- No UV
- Superior ESD protection
- Eutectic die band, lower Rth.
- ROHS compliant –Lead-free.
- Instant light (less than 100ns)

Radiation Pattern

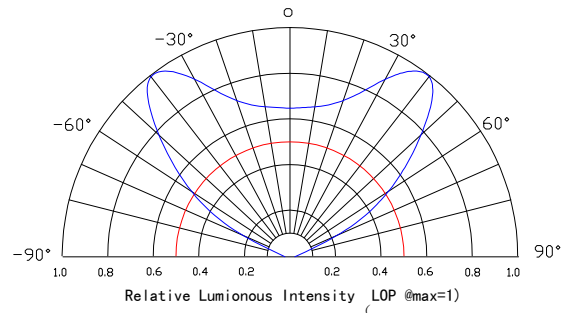

Package Dimensions

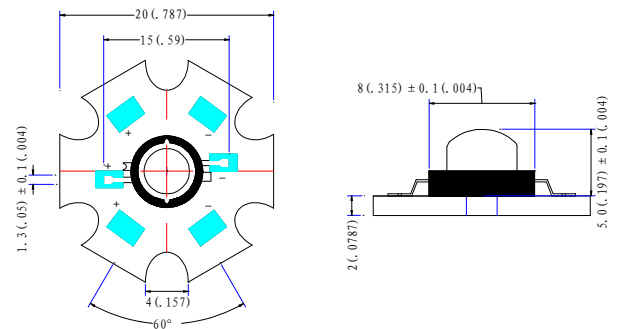

Applications

- Reading lights (car, bus, aircraft)
- Portable (flashlight, bicycle)
- orientation
- Mini-accent
- Decorative
- Fiber optic alternative
- Appliance
- Sign and channel letter
- Architectural detail
- Cove lighting
- Automotive exterior (stop-Tail-turn, CHMSL, Mirror side repeat)
- Edge-lit signs (Exit, point of sale)

HIGH POWER

■ **Typical Optical/Electrical Characteristics@T_J=25°C**

Item	symbol	Condition	Min	Typ	Max	Unit
Forward Voltage	VF	IF=800mA	3.2	3.6	4.0	V
Reverse Current	IR	VR=5V			50	uA
50% Power Angle	2θ _{1/2}	IF=800mA	110	120	130	deg
Luminous Intensity	Φ _v	IF=800mA	90	110		LM
Recommend Forward Current	IF			800		mA
Chromaticity coordinates	X	IF=800mA		0.30		
	Y			0.30		
Thermal Resistance, Junction to Case	R _{jp}	IF=800mA		10		°C/W

- Notes: 1. Tolerance of measurement of forward voltage ± 0.1v
 2. Tolerance of measurement of peak Wavelength ± 2.0nm
 3. Tolerance of measurement of luminous intensity ± 15%.

■ **Absolute Maximum Rating**

Item	symbol	Absolute Maximum Rating	Unit
Forward Current	IF	800	mA
Peak Forward Current*	IFD	1200	mA
Reverse Voltage	VR	5	V
Power Dissipation	PD	3000	mW
Electrostatic discharge	ESD	± 4500	V
Operation Temperature	T _{OPR}	-30°C to +80°C	
Storage Temperature	T _{STG}	-40°C to +100°C	
Lead Soldering Temperature*	T _{SOL}	260°C for 6 Seconds Max	

- IFP Conditions :Pulse Width ≤ 10 msec duty ≤ 1/10
- All high Power emitter LED products mounted on aluminum metal-core printed circuit board, can be lighted directly ,but we do not recommend lighting the high power products for more than 5 seconds without a directly,but we do not recommend lighting the high powe products for more than 5 seconds without a appropriate heat dissipation equipment.
- Re-flow, wave peak and soak-stannum soldering etc. is not suitable for this products.
- Suggest to solder it by professional high power LED soldering machine.
- Can use invariable -temperature searing-iron with soldering condition: ≤ 260 degree less than 3 seconds.

HIGH POWER

■ Typical optical/Electrical Characteristics Curves (Tj=25°C Unless Otherwise Noted)

